

LS-B Series

High performance,
cost effective
factory solutions

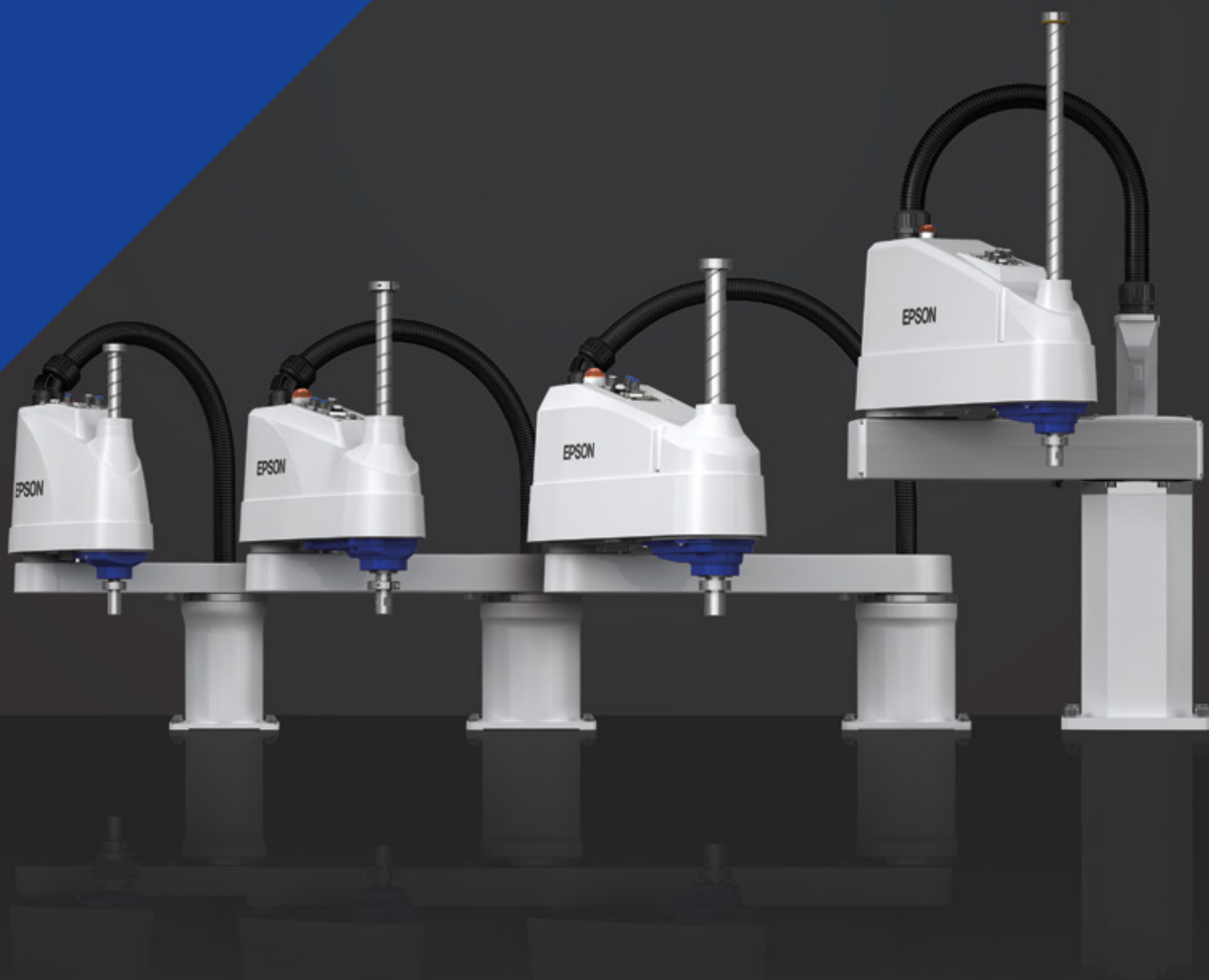

EPSON[®]
EXCEED YOUR VISION

Value and performance

The Epson LS-B series is both powerful and cost-effective with its performance, as well as with its low acquisition and operating costs.

The Epson LS-B 4 axis robot (including a controller) is a worthwhile investment and is designed to work in environments, which were typically reserved for linear systems, or other less flexible machines.

Advantages at a glance

- Batteryless motor unit
- Space and energy saving
- New top-of-arm layout
- Built-in camera cable
- Reduced cable height



Batteryless motor unit

Minimise downtime and reduce overall cost of ownership.

Built-in camera connector

It all comes integrated with an RJ45 Ethernet connector for easy vision system setup.

User-friendly top-of-arm layout

An extra ethernet port and screw holes make for easy top of arm equipment mounting and welcome extratime saving. Everything is spaced out for easier than ever access.

Reduced cable height

The space-saving, compact design cuts cabling down to size: ideal for hard to reach work cell layouts.



The range

Advanced Epson LS-B Series

Precision guaranteed. The four LS-B models vary in load capacity and range. Each robot is also available in a cleanroom version.

What's included:

Epson robot and controller

1 Epson RC+ program CD including simulator

2 mounting bracket sets for the RC90 robot controller

1 set of 3m power and signal cables

1 emergency stop plug

1 standard I/O plug

1 plug set for user cabling

1 backup disk for the RC90 robot controller

1 USB programming cable (RC90)

User manuals on CD

1 Installation/safety manual



LS3-B SCARA Robot

Payload: 3kg

Range: 400mm

Standard Version or Cleanroom Version



LS6-B SCARA Robot

Payload: 6kg

Range: 500mm, 600mm and 700mm

Standard Version or Cleanroom Version

Optional extras:

Extended power and signal cable (5m/10m)

Tool adapter for easy installation of end effectors on Z axis



LS10-B SCARA Robot

Payload: 10kg

Range: 600mm, 700mm and 800mm

Standard Version or Cleanroom Version



LS20-B SCARA Robot

Payload: 20kg

Range: 800mm and 1000mm

Standard Version or Cleanroom Version

Technical specification



Model name		LS3-B
Model number		LS3-B401S (LS3-B401C)
Arm length (J1+J2) mm		400
Payload* ¹	Rated (kg)	1
	Max. (kg)	3
Repeatability	(J1+J2) mm	+/- 0.01
	(J3) mm	+/- 0.01
	(J4) deg	+/- 0.01
Standard cycle time (s)* ²		0.42
Max. operation speed	(J1+J2) mm/s	7200
	(J3) mm/s	1100
	(J4) deg/s	2600
(J4) allowable moment of inertia* ³	Rated (kg m ²)	0.005
	Max. (kg m ²)	0.05
(J3) down force (N)		100
Installation Environment		Standard or Clean (ISO4, Not ESD applied)
Mounting type		Floor
Weight (kg) (cables not included)		14
Applicable Controller		RC90-B
Installed wire for customer use		D-sub 15 pin x1, RJ45 8 pin (CAT 5e) x1
Installed pneumatic tube for customer use		Ø6mm x2, Ø4mm x1: 0.59Mpa (6kgf/cm ²)
Power	(V)	AC200-240
Power Consumption* ⁴	(kVA)	1.1
Cable length (m)* ⁵		3, 5, 10
Safety standard		EU Directive Complied * ⁵ , KC, KCs ANSI/RIA R15.06-2012, NFPA 79 (2007 Edition)

J1 = Axis 1 J3 = Axis 3

J2 = Axis 2 J4 = Axis 4

*1 : Do not apply the load exceeding the maximum payload.

*2 : Cycle time based on round-trip arch motion (300mm horizontal, 25mm vertical) with Accel 120% and 2kg payload (path coordinates optimised for maximum speed). Rounded down to the third decimal place.

*3 : If the centre of gravity is at the centre of each arm. If the centre of gravity is not at the centre of each arm, set the eccentric quantity using INERTIA command.

*4 : It depends on operating environment and operation program.

*5 : Standard cable only. There is no setting of the flexible cable. If necessary, a new MT or product planning is necessary.

Top view

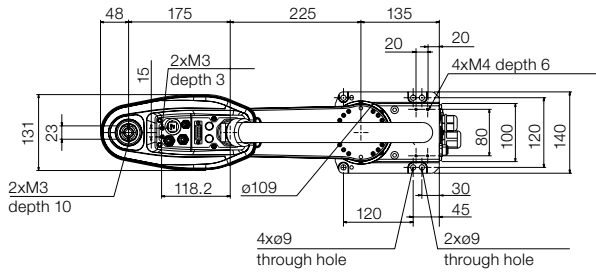

Working range, LS3-B401S

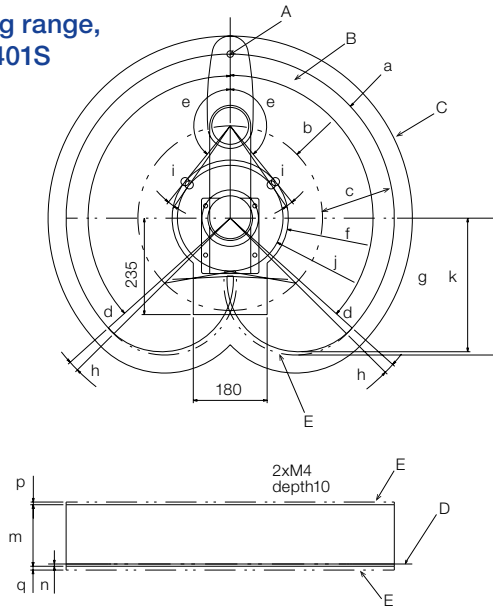

Working range, Epson SCARA LS3-B

		LS3-B401*	
a	Arm #1 + Arm #2 length (mm)	400	
b	Arm #1 length (mm)	175	
c	Arm #2 length (mm)	225	
d	(J1) motion angle (deg)	132	
e	(J2) motion angle (deg)	141	
f	Motion range (deg)	141.6	
g	Motion range at the rear (deg)	325.5	
h	Angle of the (J1) mechanical stop (deg)	2.8	
i	Angle of the (J2) mechanical stop (deg)	4.2	
j	Mechanical stop area (mm)	128.8	
k	Mechanical stop area at the rear (mm)	333.5	
m	(J3) motion range (mm)	Standard	150
		Clean	120
n	Distance from the base mounting face (mm)	Standard	5.5
		Clean	9.5
p	(J3) mechanical stop area upper end (mm)	Standard	6.5
		Clean	10.5
q	(J3) mechanical stop area lower end (mm)	Standard	6.5
		Clean	10.5

A = Centre of Joint #3
B = Motion range

C = Maximum range
D = Base mounting face

E = Area limited by a mechanical stop

Side view

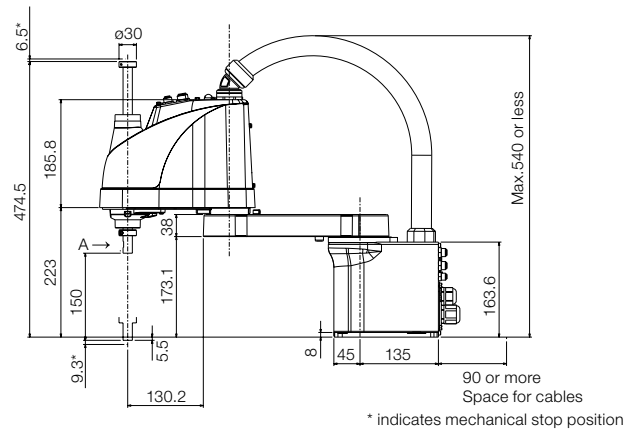

Rear view

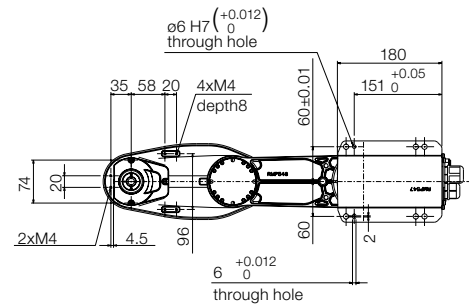

Flange (standard)

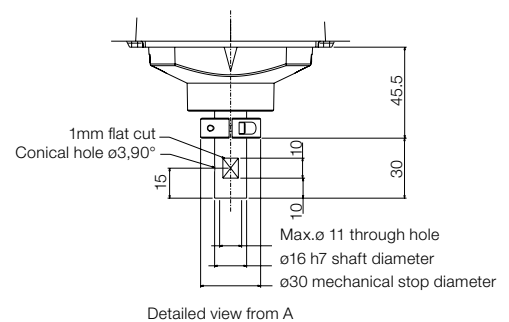

Flange (cleanroom)

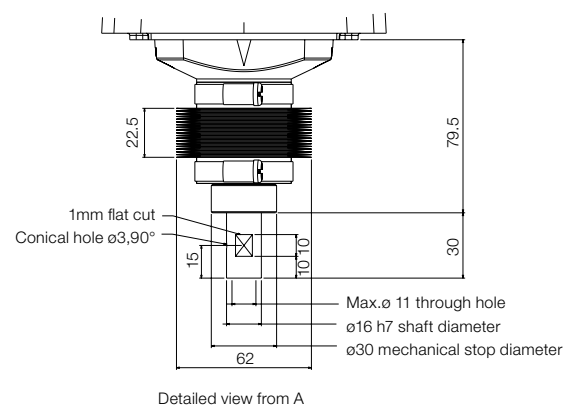

Technical specification



Model name		LS6-B		
Model number		LS6-B502S (LS6-B502C)	LS6-B602S (LS6-B602C)	LS6-B702S (LS6-B702C)
Payload*1	Rated (kg)	2		
	Max. (kg)	6		
Arm length (J1+J2)		500	600	700
		(J1)	225	325
		(J2)	275	
Repeatability	(J1+J2) mm	+/- 0.02		
	(J3) mm	+/- 0.01		
	(J4) deg	+/- 0.01		
Standard cycle time (s)*2		0.41	0.42	0.43
Max. motion range	(J1) deg	+/- 132		
	(J2) deg	+/- 150		
	(J3) mm	200 (Clean 170)		
	(J4) deg	+/- 360		
Max. operation speed	(J1+J2) mm/s	7120	7850	8590
	(J3) mm/s	1100		
	(J4) deg/s	2000		
(J4) allowable moment of inertia*3	Rated (kg m ²)	0.01		
	Max. (kg m ²)	0.12		
(J3) down force (N)		100		
Mounting type		Floor		
Installation Environment		Standard or Clean (ISO4, Not ESD applied)		
Weight (kg) (cables not included)		17	17	18
Applicable Controller		RC90-B		
Cable length (m)*4		3, 5, 10		
Installed wire for customer use		D-sub 15 pin x1, RJ45 8 pin (CAT 5e) x1		
Installed pneumatic tube for customer use		Ø6mm x2, Ø4mm x1		
Safety standard		EU Directive Complied *5, KC, KCs ANSI/RIA R15.06-2012, NFPA 79 (2007 Edition)		

J1 = Axis 1 J3 = Axis 3

J2 = Axis 2 J4 = Axis 4

*1 : Do not apply the load exceeding the maximum payload.

*2 : Cycle time based on round-trip arch motion (300mm horizontal, 25mm vertical) with Accel 120% and 2kg payload (path coordinates optimised for maximum speed). Rounded down to the third decimal place.

*3 : If the centre of gravity is at the centre of each arm. If the centre of gravity is not at the centre of each arm, set the eccentric quantity using INERTIA command.

*4 : Standard cable only. There is no setting of the flexible cable. If necessary, a new MT or product planning is necessary.

*5 : Because the robot is built and used in the customer's equipment, therefore robot shipment includes a 'Declaration of Incorporation of Partly Completed Machinery'.

Top view

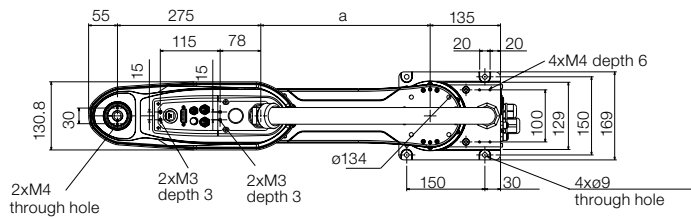

Side view

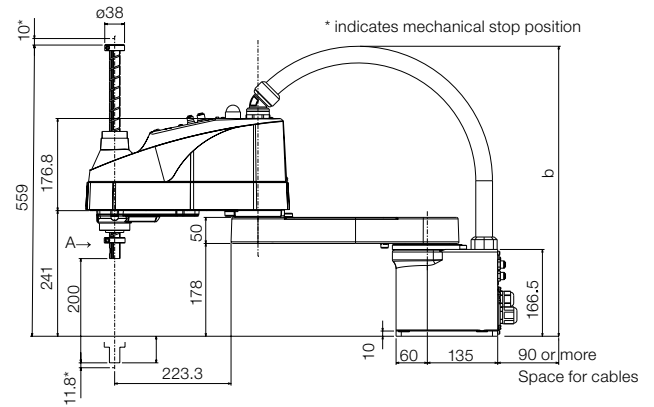

Working range, LS6-B502S

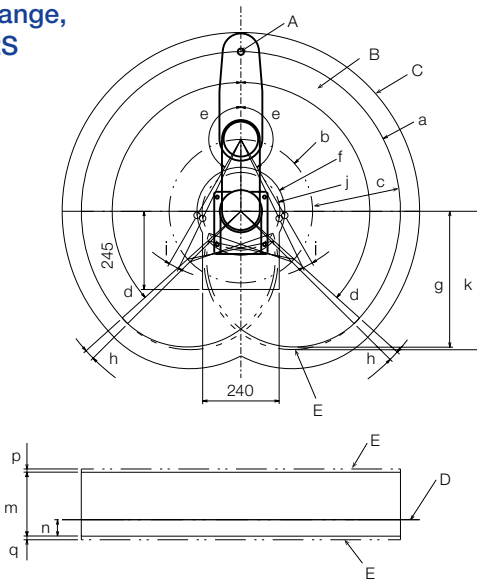

Rear view

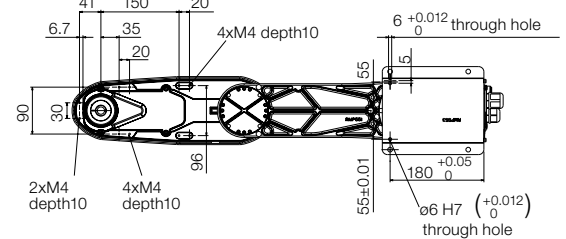

Working range, Epson SCARA LS6-B

		LS6-B502*	LS6-B602*	LS6-B702*
a	Arm #1 + Arm #2 length (mm)	500	600	700
b	Arm #1 length (mm)	225	325	425
c	Arm #2 length (mm)		275	
d	(J1) motion angle (deg)		132	
e	(J2) motion angle (deg)		150	
f	Motion range (deg)	138.1	162.6	232
g	Motion range at the rear (deg)	425.6	492.5	559.4
h	Angle of the (J1) mechanical stop (deg)		2.8	
i	Angle of the (J2) mechanical stop (deg)		4.2	
j	Mechanical stop area (mm)	121.8	142.5	214
k	Mechanical stop area at the rear (mm)	433.5	504	574.5
m	(J3) motion range (mm)	LS6-B**2S	200	
		LS6-B**2C	170	
n	Distance from the base mounting face (mm)	LS6-B**2S	51	
		LS6-B**2C	530	
p	(J3) mechanical stop area upper end (mm)	LS6-B**2S	10	
		LS6-B**2C	6	
q	(J3) mechanical stop area lower end (mm)	LS6-B**2S	11.8	
		LS6-B**2C	9.8	

Flange (standard)

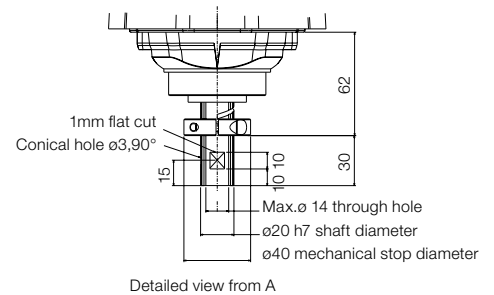

Flange (cleanroom)

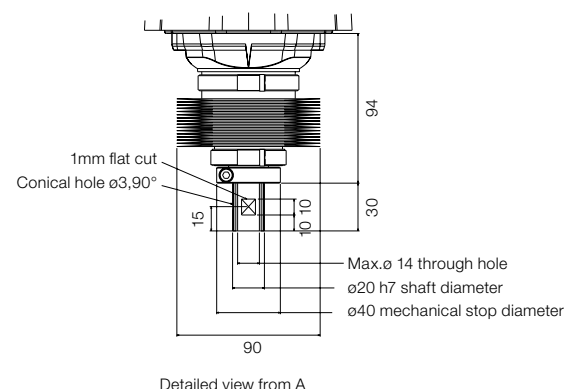

A = Centre of Joint #3
B = Motion range

C = Maximum range
D = Base mounting face

E = Area limited by a mechanical stop

Technical specification



Model name		LS10-B		
Model number		LS10-B60*S (LS10-B60*C)	LS10-B70*S (LS10-B70*C)	LS10-B80*S (LS10-B80*C)
Arm length (J1+J2)		600	700	800
Payload*1	Rated (kg)	5		
	Max. (kg)	10		
Repeatability	(J1+J2) (mm)	+/- 0.02	+/- 0.02	+/- 0.025
	(J3) mm	+/- 0.01		
	(J4) deg	+/- 0.01		
Standard cycle time (s)*2		Less than 0.389	Less than 0.409	Less than 0.449
Max. operation speed	(J1+J2) mm/s	9100	9800	10500
	(J3) mm/s	1100		
	(J4) deg/s	2500		
Join#4 allowable moment of inertia*3	Rated (kg m ²)	0.02		
	Max. (kg m ²)	0.3		
(J3) down force (N)		200		
Mounting type		Floor		
Installation Environment		Standard or Clean (ISO4, Not ESD applied)		
Weight (kg) (cables not included)		22	22	23
Applicable Controller		RC90-B		
Cable length (m)*4		3, 5, 10		
Installed wire for customer use		D-sub 15 pin x1, RJ45 8 pin (CAT 5e) x1		
Installed pneumatic tube for customer use		Ø6mm x2, Ø4mm x1		
Power	(V)	AC200-240		
Power Consumption*4	(kVA)	1.8		
Cable length (m)*5		3, 5, 10		
Safety standard		EU Directive Complied *5, KC, KCs ANSI/RIA R15.06-2012, NFPA 79 (2007 Edition)		

J1 = Axis 1 J3 = Axis 3

J2 = Axis 2 J4 = Axis 4

*1 : Do not apply the load exceeding the maximum payload.

*2 : Cycle time based on round-trip arch motion (300mm horizontal, 25mm vertical) with Accel 120% and 2kg payload (path coordinates optimised for maximum speed).

*3 : If the centre of gravity is at the centre of each arm. If the centre of gravity is not at the centre of each arm, set the eccentric quantity using INERTIA command.

SEG Internal Info:

*4 : It depends on operating environment and operation program.

*5 : Standard cable only. There is no setting of the flexible cable. If necessary, a new MT or product planning is necessary.

Top view

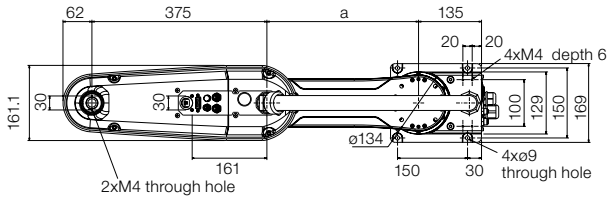

Side view

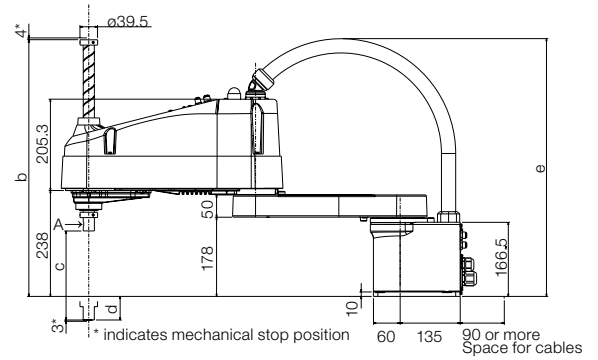

Working range, LS10-B602S

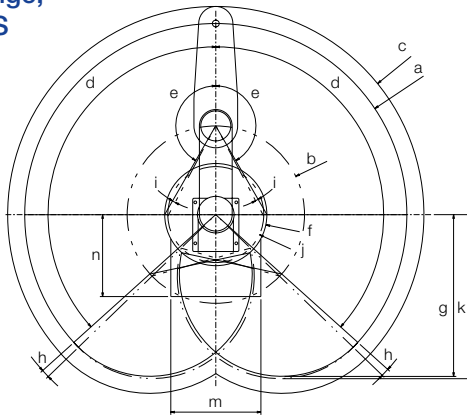

Rear view

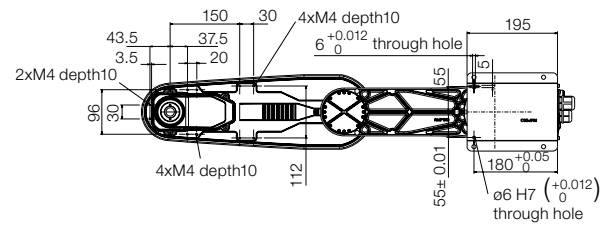

Working range, Epson SCARA LS10-B

		LS10-B60**	LS10-B70**	LS10-B80**
a	Arm #1 + Arm #2 length (mm)	600	700	800
b	Arm #1 length (mm)	225	325	425
c	Arm #2 length (mm)		275	
d	(J1) motion angle (deg)		132	
e	(J2) motion angle (deg)		150	
f	Motion range (deg)	138.1	162.6	232
g	Motion range at the rear (deg)	425.6	492.5	559.4
h	Angle of the (J1) mechanical stop (deg)		2.8	
i	Angle of the (J2) mechanical stop (deg)		4.2	
j	Mechanical stop area (mm)	121.8	142.5	214
k	Mechanical stop area at the rear (mm)	433.5	504	574.5
m	(J3) motion range (mm)	LS10-B**2S	200	
		LS10-B**3S	300	
n	Distance from the base mounting face (mm)	LS10-B**2*	53	
		LS10-B**3*	153	
p	(J3) mechanical stop area upper end (mm)	LS10-B***S	4	
q	(J3) mechanical stop area lower end (mm)		3	

A = Centre of Joint #3
B = Motion range

C = Maximum range
D = Base mounting face

E = Area limited by a mechanical stop

Flange (standard)

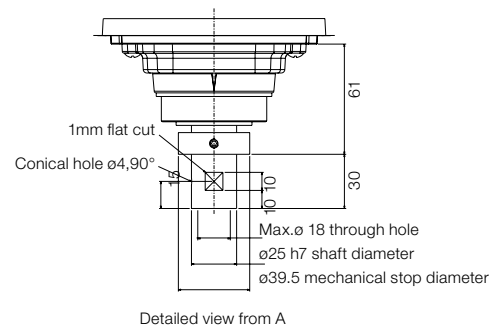

Flange (cleanroom)

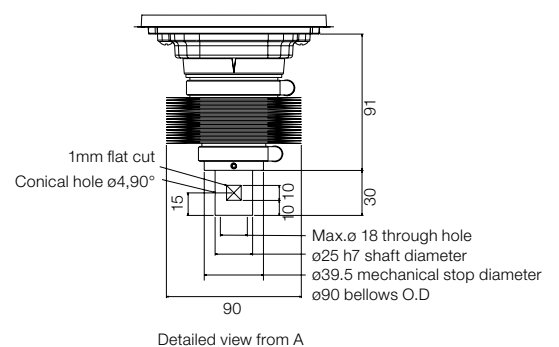

Technical specification



Model name		LS20-B	
Model number		LS20-B804S (LS20-B804C)	LS20-BA04S (LS20-BA04C)
Arm length (J1+J2)		800	1000
Payload*1	Rated (kg)	10	
	Max. (kg)	20	
Repeatability	(J1+J2) (mm)	+/- 0.025	
	(J3) mm	+/- 0.01	
	(J4) deg	+/- 0.01	
Standard cycle time (s)*2		0.39	0.43
Max. operation speed	(J1+J2) mm/s	9940	11250
	(J3) mm/s	2300	
	(J4) deg/s	1400	
(J4) allowable moment of inertia*3	Rated (kg m ²)	0.05	
	Max. (kg m ²)	1	
(J3) down force (N)		250	
Mounting type		Floor	
Installation Environment		Standard or Clean (ISO4, Not ESD applied)	
Weight (kg) (cables not included)		48	51
Applicable Controller		RC90 (nonpolarity)	
Installed wire for customer use		D-sub 15 pin x1, 9 pin x1, RJ45 8 pin (CAT 5e) x1	
Installed pneumatic tube for customer use		Ø6mm x2, Ø4mm x1	
Power	(V)	AC200-240	
Power Consumption*4	(kVA)	2.4	
Cable length (m)*5		3, 5, 10	
Safety standard		EU Directive Complied *5, KC, KCs ANSI/RIA R15.06-2012, NFPA 79 (2007 Edition)	

J1 = Axis 1 J3 = Axis 3

J2 = Axis 2 J4 = Axis 4

*1 : Do not apply the load exceeding the maximum payload.

*2 : Cycle time based on round-trip arch motion (300mm horizontal, 25mm vertical) with Accel 120% and 2kg payload (path coordinates optimised for maximum speed).

*3 : If the centre of gravity is at the centre of each arm. If the centre of gravity is not at the centre of each arm, set the eccentric quantity using INERTIA command.

*4 : It depends on operating environment and operation program.

Internal use only:

*5 : Standard cable only. There is no setting of the flexible cable. If necessary, a new MT or product planning is necessary.

Top view

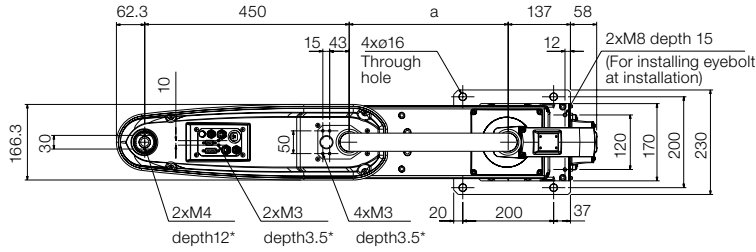

Working range, LS20-B

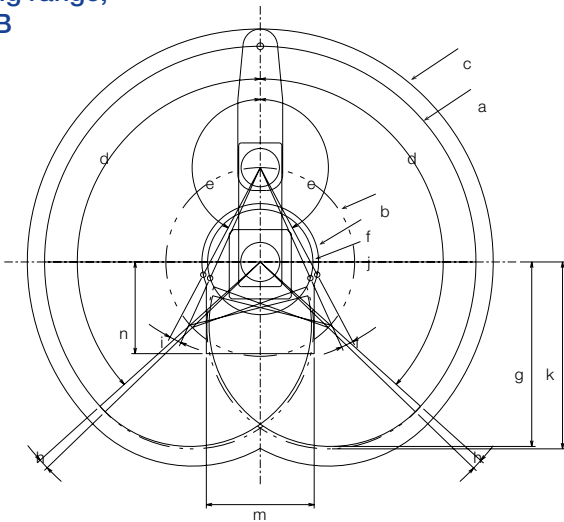

Working range, Epson SCARA LS20-B

		LS20-B804*	LS20-BA04*
a	Arm #1 + Arm #2 length (mm)	800	1000
b	Arm #1 length (mm)	350	550
c	Arm #2 length (mm)	450	
d	(J1) motion angle (deg)	132	
e	(J2) motion angle (deg)	152	
f	Motion range (deg)	216.5	260.7
g	Motion range at the rear (deg)	684.2	818
h	Angle of the (J1) mechanical stop (deg)		2
i	Angle of the (J2) mechanical stop (deg)		3.6
j	Mechanical stop area (mm)	195.3	232.8
k	Mechanical stop area at the rear (mm)	693.1	832.1
m	(J3) motion range (mm)	LS20-B***S: 420 LS20-B***C: 390	
n	Distance from the base mounting face (mm)	LS20-B***S: 26.5 LS20-B***C: 33.7	
p	(J3) mechanical stop area upper end (mm)	LS20-B***S: 4 LS20-B***C: 3.2	
q	(J3) mechanical stop area lower end (mm)	LS20-B***S: 3 LS20-B***C: 1.8	

A = Centre of Joint #3
B = Motion range

C = Maximum range
D = Base mounting face

E = Area limited by a mechanical stop

Side view

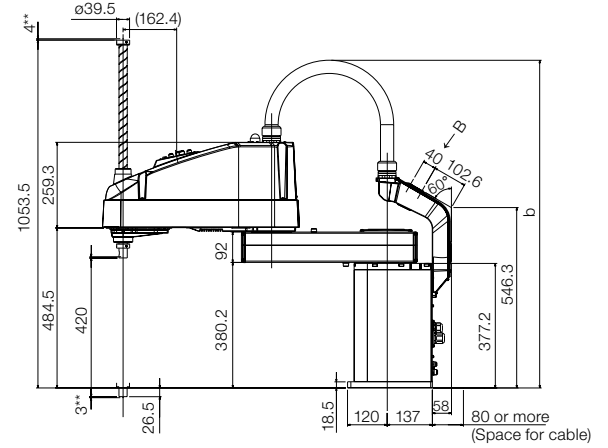

Rear view

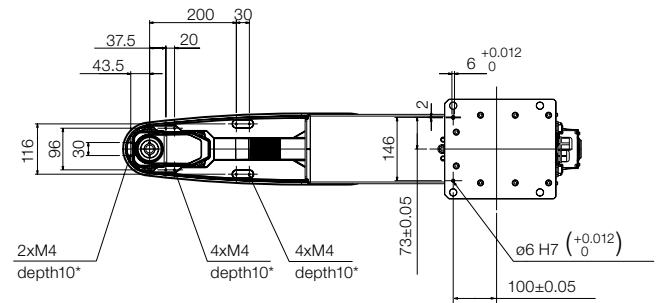

Flange (standard)

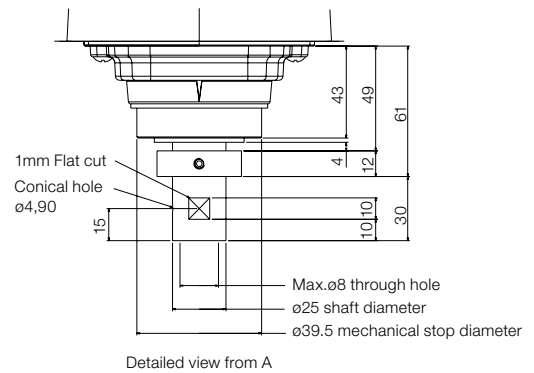

Flange (cleanroom)

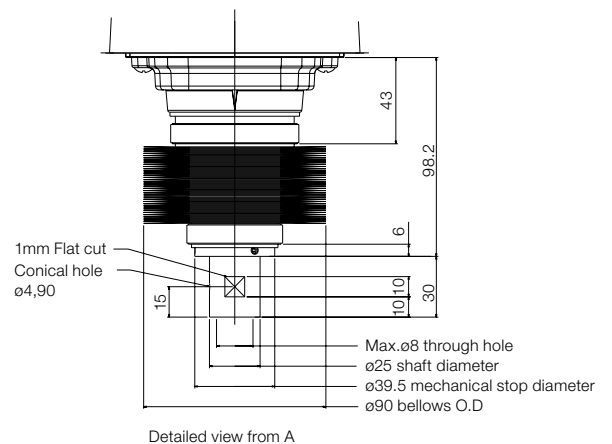

RC90-B controller



RC90-B controller

Ports	1x USB memory, 1x USB device 1x 10/100 base T-Ethernet 24/16 standard I/O channels – 8/8 as remote RS-232C Standard 1x channel
CPU	32-bits Microprocessor
Hardware Option	Teach Pendant 2
Expansion card options	<p>I/O expansion 24/16, 2 additional cards possible</p> <p>I/O slave fieldbus cards EtherCat, DeviceNet, Profibus, ProfiNet, CC-Link, Ethernet / IP, 1 additional card of each type possible</p> <p>I/O fieldbus master cards Profibus, DeviceNet, Ethernet / IP, 1 additional card of each type possible</p> <p>RS-232C serial interface 2 channels per card, 2 additional cards possible</p>
Software options	RC+ API 7.0 previously VB Guide External Control Point Motion (ECP) GUI Builder
Development environment	Epson RC+ 7.0
Programming language	Epson SPEL+ multitasking-capable
Connection values	AC 200 V to AC 240 V, one-phase 50/60 Hz
Power consumption	Up to 2,500 VA – depending on manipulator model
Ambient temperature	5-40°C
Relative humidity	20% to 80% – non-condensing
Safety equipment	<p>Emergency Stop button, safety door entry, low power mode, generator brake</p> <p>Error detection Encoder cable break</p> <p>Detectors Motor overload, motor speed error, irregular motor torque (manipulator out of control), overheating of a motor driver module, positioning overrun – servo error, speed overrun – servo error, CPU error, memory checksum error, relay drop-out, excess voltage, mains voltage outage, temperature deviation, fan error</p>
Certifications	CE ANSI RIA R15.06-1999 EC Machinery Directive 2006/42/EC
Dimensions	380 x 350 x 180mm
Price	Included in SCARA Light price

Small, compact and flexible, the RC90-B is ideal for small work cells and can be installed in a control cabinet. This flexible application can be operated as a stand alone or integrated system.

Use as a slave within a network or as a master to control multiple robots and peripheral devices. It comes with serial interfaces, expansion I/O cards and an Ethernet port, but should you require additional inputs/outputs, you can expand your system cost-effectively and flexibly to suit your needs.



TP2 mobile operating unit



I/O expansion

I/O expansion card

I/O expansion cable kit

I/O expansion kit
(card, block and cable)



RS-232C serial interface



Fieldbus cards

Slave

Profibus, ProfiNet, DeviceNet,
CC-Link, EtherCat

EtherNet/IP

Master

Profibus, DeviceNet, Ethernet/IP

Epson RC+ 7.0 development interface – powerful, efficient, intuitive

Thanks to its intuitive Windows control interface, open structure and integrated image processing, programming applications is incredibly quick and easy.

The unique Epson-developed SPEL+ script language, enables you to program a wide range of robot motions, from simple pick & place application to complex multi-manipulator line control.

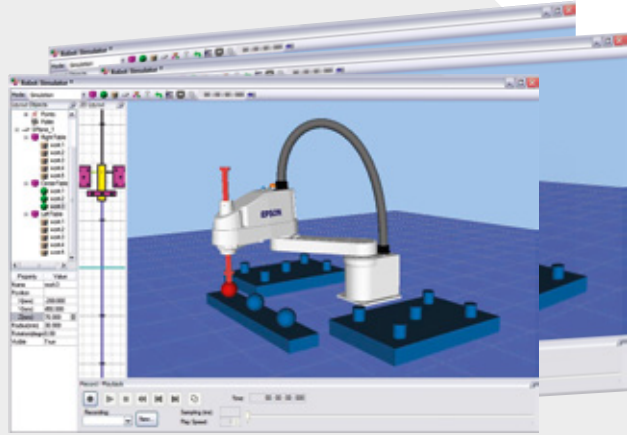

The Epson RC+ Simulator allows you to carry out risk-free testing, comparison and process visualisation before any robot implementation.

Integrated software tools for the Epson RC+ 7.0 development environment

Command

One-line command editor.

Compiler

Programme checking (syntax, definition, value range, and many more).

Debugger

Programme with stop points / step mode.

DLL-functions

Access to external DLL functions.

Editor

Create SPEL+ programs:

Online help, syntax check, label lists, detection and colour display of keywords, parameters and comments, parameter list, definition jump.

Error text editor

Creation of your own, application-specific, error messages.

File management

Create and access files and databases (Excel, Access, SQL).

IO label editor

Edit names for I/O / markers / field bus I/O for the data sizes bit, byte, and word.

IO monitor

Display the status of I/O / markers / field bus I/O for the data sizes bit, byte, and word. Allows you to create special user displays.

Macro editor

Create a SPEL+ program as a programming aid.

Robot manager

Contains all information and control elements relevant to robots – inserted in clear windows: Set-up, edit points, loop parameters, tool and robot coordinate systems, load capacity and moment of inertia. The robot trip points can be used to switch power on and off, complete a reset or complete a home run.

Stack editor

Display the program branches.

System history

Record errors, events and warnings (diagnostics).

Task manager

Display called multi-tasks, traps, and their statuses, display current program line.

Variable editor

Display / Edit current variable values.

Maintenance manager

Create / Load / Display backups, controller reset.

Simulator

Plan and visualise processes, validate programs.

Software options

Conveyor tracking

Synchronise position with conveyor running.

External control point (ECP)

Guide the workpiece contour easily and precisely along an external point.

Force sensing

Real-time robot force measurement.

GUI builder

For the fast, easy creation of your own user interface based on the Epson SPEL+ programming language.

Optical character recognition (OCR)

Reliably detect fonts and symbols and check printing – even under challenging conditions.

PG motion system

Read conveyor speeds via encoders.

RC+ API

Integrate your application in external software, develop user interfaces, and use databases.

Security option

Increased security through user management and usage control.

Vision guide 7.0

Powerful Epson image processing system.

About Epson

Epson Robotic Solutions is one of the leading suppliers of high-tech robot systems that are renowned worldwide for their reliability. The product range includes six-axis, SCARA, entry-level LS-, T- and VT-series robots. Also, the special Epson-developed Spider and N-series robots as well as the pioneering Dual Arm robot. Added to this are image processing controls and the Epson Force Sensor for force-controlled applications.

This gives Epson Robotic Solutions one of the most comprehensive ranges of high-precision industrial robots in the world, making them a technological pioneer for intelligently controlled automation processes.

Technological pioneer

1982

Epson SCARA robots freely available in Japan for the first time

1986

First cleanroom robot class 1

1997

First PC-based controller

2008

Inventor of the right or left arm-optimised G3 SCARA robot

2009

Inventor of the spider – a unique SCARA robot with no dead zones

2013

First application of Epson QMEMS® sensors in robotics, reducing 6-axis kinematics vibrations

2014

Epson Compact Vision CV2: Epson's own ultra-fast image processing computer

2016

Epson N2 series: World's first 6-axis robot with folding arm – extremely compact and space-saving

2017

Epson Dual Arm robot with an arm geometry inspired by human physiology, as well as integrated sensors such as cameras, force sensors, and accelerometers

Pre- and after-sales support

Feasibility studies for maximum planning and project security

Support for planning and implementation

Introductory seminars, programming/maintenance courses, operator training

Inspection and individual maintenance concepts

Hotline service, on-site repair service

Central spare part stocking

Ensure your production line hits top gear

Epson robot systems: precise, fast and reliable

Our robots pallet, saw, mill, drill, grind, assemble, move and build together. They work precisely and at a breathtaking speed in all these and many other applications – often for up to 24 hours a day.

Our product portfolio includes one of the most extensive SCARA model ranges worldwide, 6-axis robots, controllers and software.



Epson Spider robots

The economic miracle. Thanks to its unique design, the Epson Spider can reach every corner of its workspace while achieving unmatched cycle times.



Epson SCARA robots

Precise working even at high speeds. Compact and powerful, Epson has the world's largest range of SCARA robots – with over 400 models.

Discover the full potential of your Epson robot systems

As a service, we offer a comprehensive pre and after-sales support program, including:

Feasibility studies for maximum planning and project security

Support for planning and implementation

Introductory seminars, programming/maintenance courses, operator training

Inspection and individual maintenance concepts

Hotline service, on-site repair service

Central spare part stocking

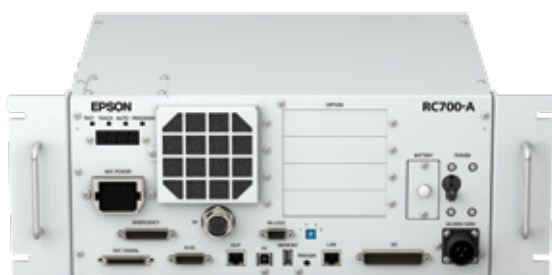

Epson controllers

Strong performance in a small space. Epson controllers are based on a robust, integrated system and can control manipulators and peripherals.



Epson 6-axis robot

Flexibility through rotating axes. Unrivalled point and track accuracy enable complex work processes to be precisely executed.

Epson Industrial Solutions Centre – find your solution

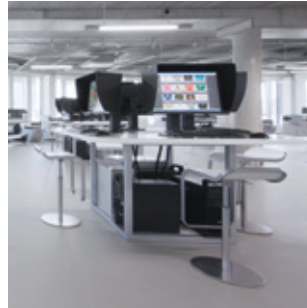

Experience all our Epson robots in action. Build, simulate and improve your automation application in a workshop cell, with help from our experts. The cell can be controlled and networked using all conventional fieldbus systems. In addition, we can supply you with modern peripherals such as a vision and conveyor tracking system.

Make an appointment

Call us on
+49 2159 5381800

or send an email to
info.rs@epson.de

Epson Deutschland GmbH
Robotic Solutions Division
Otto-Hahn-Straße 4
40670 Meerbusch

Phone: **+49 2159 5381800**
Fax: **+49 2159 5383170**
E-Mail: **info.rs@epson.de**
www.epson.de/robots

Epson America Inc.
www.epsonrobots.com

Seiko Epson Corp
<http://global.epson.com/products/robots/>

Epson China Co, Ltd.
www.epson.com.cn/robots/

Committed to corporate and social responsibility

Epson is committed to developing environmentally conscious products, which means that sustainability is considered from conception to completion. We help customers recognise the environmental gains brought on by technology, whether it is redefining manufacturing through innovative robotics, saving energy with our office printing technology or revolutionising textile printing with digital solutions.

We are committed to all 17 United Nations' sustainable development goals and to the aims of the circular economy. We offer sustainable innovations because we recognise that the choices we make as organisations, individuals or a society will be essential to our shared success.

The content of this publication has not been approved by the United Nations and does not reflect the views of the United Nations or its officials or Member States www.un.org/sustainabledevelopment



For further information please contact your local Epson office or visit www.epson-europe.com

Algeria (+2213) 770 938 617 Austria 01 253 49 78 333 Belgium +32 (0)2 792 04 47 Czech 800/142 052 Denmark 44 50 85 85 East Africa (+254) 734 354 075
Finland 0201 552 091 France 09 74 75 04 04 (Cost of local call, operator charges may apply) Germany +49 (0) 2159/92 79 500 Greece 210-8099499
Hungary 06800 147 83 Ireland 01 436 7742 Israel (+972)-3-5751833 Italy 02-660321 10 (0,12 €/min) Luxembourg +352 27860692 Middle East +9714 8872172
Morocco (+212) 661 31 11 18 Netherlands +31 (0)20 708 5099 Norway +47 67 11 37 00 Poland 0-0-800 4911299 (0,16 zł/min) Portugal 707 222 111
Russia (095) 777-03-55 Slovakia 0850 111 429 Southern Africa (+2711) 465-9621 Spain 93 582 15 00 Sweden 0771-400135 (Mobilsamtal – 0,99 kr/min,
Lokala samtal – 0,30 kr/min, Utlandssamtal – 0,89 kr/min) Switzerland 022 592 7923 Tunisia (+216) 9833 3571 Turkey (0212) 3360303
United Kingdom 0871 222 6702 West Africa (+234)8020727843

Trademarks and registered trademarks are the property of Seiko Epson Corporation or their respective owners.
Product information is subject to change without prior notice.

EPSON®