

Prosix N2 and N6 Series: 6-axis robot

Maximum efficiency,
minimum footprint

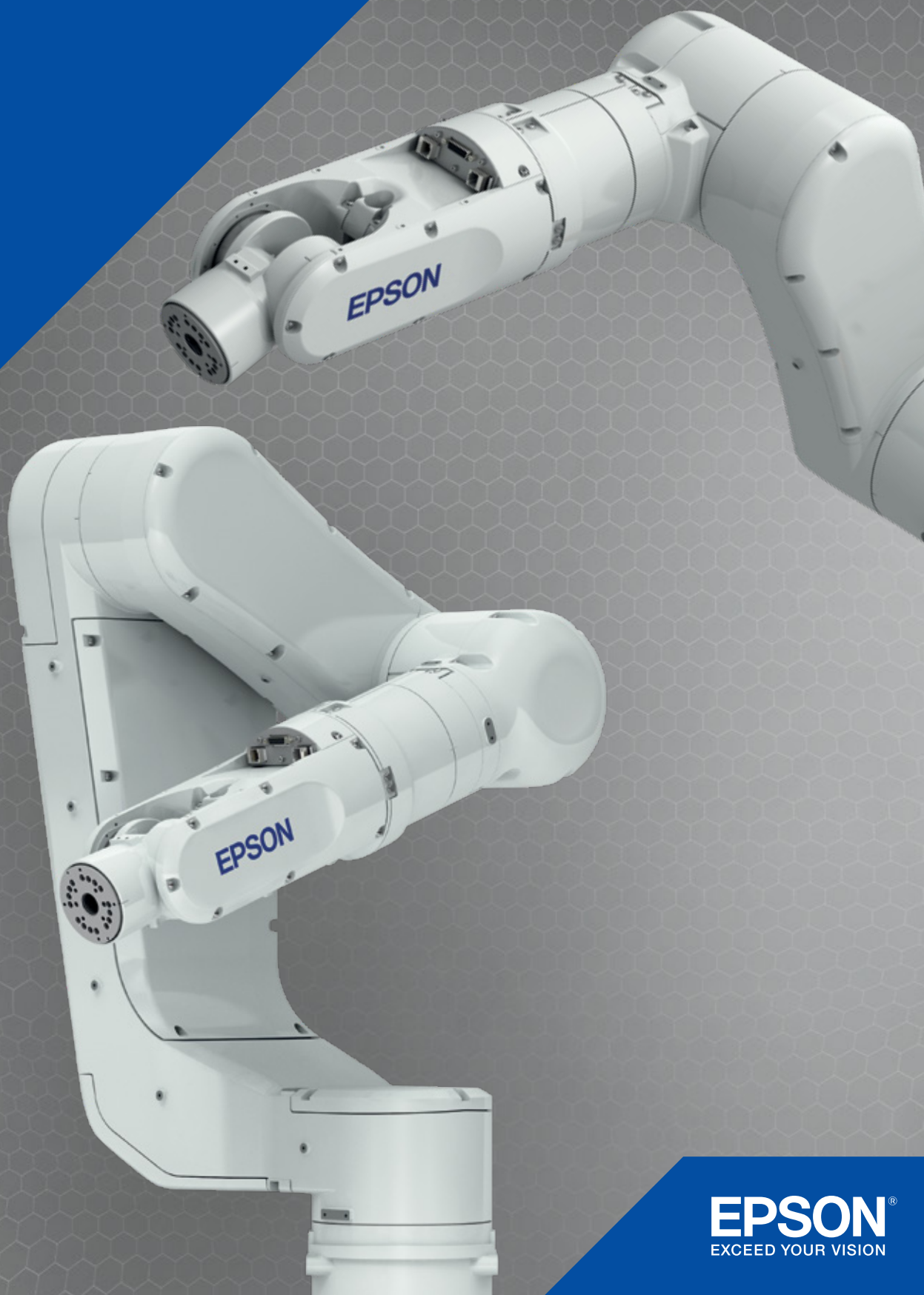

EPSON[®]
EXCEED YOUR VISION

The innovative new N-Series

Factory space costs money. The revolutionary new N-Series robot from Epson is extremely agile and occupies less space than any other 6-axis robot ever built.

The N-Series kinematics enable increased productivity in even smaller work cells. Able to reach every point within its working area without wasteful extra movements, it covers an action field which would normally require a 6-axis robot with a significantly longer arm.

Why choose the Epson N-Series?

World's first 6-axis robot with folding arm – compact and space saving.

Short cycle times via “short cut” movements.

Needs less floor area compared to conventional 6-axis robots.

Virtually no risk of collision with other peripherals or the work cell thanks to optimum mobility and fewer interference contours.

Maximum precision and consistently stable quality thanks to Epson QMEMS® sensor technology and Epson Smart Motion.

Extremely manoeuvrable with folding arm

A traditional 6-axis robot works in an external orientation – the arm must fully extend for reorientation. This movement takes extra time and means the robot takes up more space.

In the new Epson N-Series, the second axis is oriented inwards, thus moving the centre of rotation downwards. This means the second axle shaft can travel through the zero position.

This type of manoeuvrability, along with the robot's small footprint, is totally unique and means a highly-efficient work process.

Strong and silent

Epson QMEMS® sensor technology and Epson Smart Motion Motor Management.

These fast, powerful, 6-axis robots feature revolutionary Motor Management from Epson and, for the first time, QMEMS® technology, which uses high-precision motion sensors.

QMEMS®-equipped robots enable exceptionally quiet and vibration-free travel, even under load and at high speeds. The benefit of this is improved production throughput and consistently stable quality in all assembly tasks.



QMEMS®
Sensor-technology inside

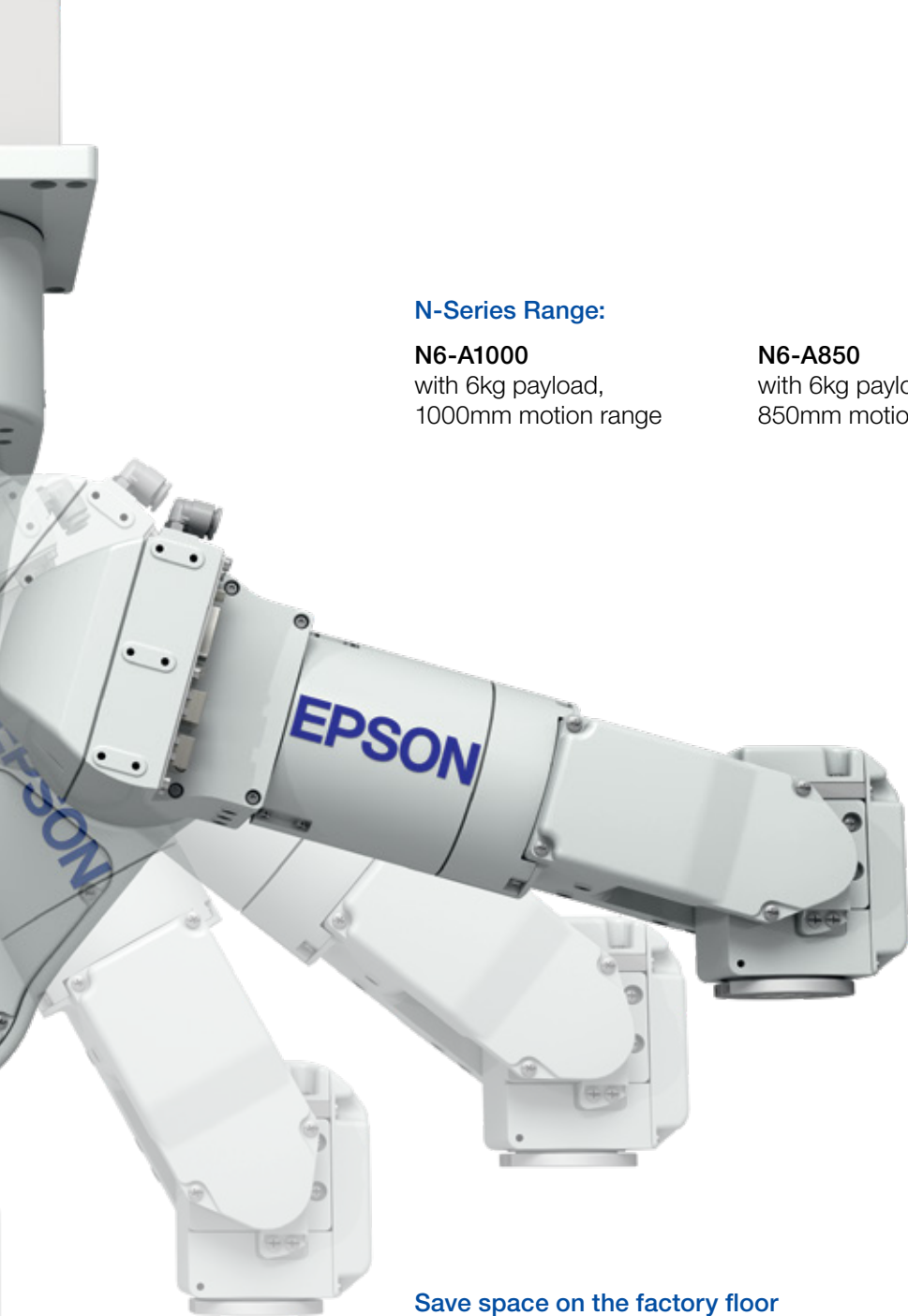

N-Series Range:

N6-A1000
with 6kg payload,
1000mm motion range

N6-A850
with 6kg payload,
850mm motion range

N2-A450
with 2.5kg payload,
450mm motion range

Save space on the factory floor

Replace with: Compared to conventional 6-axis robots, the ProSix N-Series robots require up to 75% less production space in production. Thanks to the completely new joint geometry with a foldable arm, they can reach every point of their work area without detours. They thus cover a field of action that would normally require a 6-axis machine with a significantly greater arm length.



replace with: Utilization of the action area at 100%

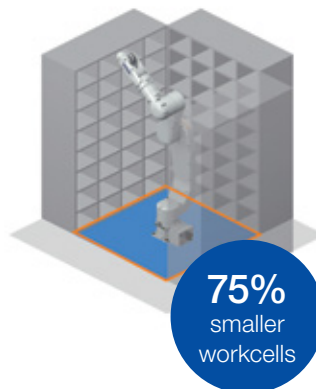

Replace with: Up to 75% less production area for the work cell

Nimble, flexible and sensitive - a great fit for your factory

Optimised for floor and ceiling installation for ultimate space and motion efficiency.

Folding design enables the arm to be rotated 180° and extended in the opposite direction using shortcut motions, reducing start-up and cycle times without risk of interference with adjoining work cells.

Epson N-Series robots are suitable for use in a range of industries and segments:

Automotive	Machine tools
Plastics	Medical devices
Metals	Semiconductors
Electronics	Food and beverage

Tailor-made robot solution for Injection Molding Machines.

The innovative N-Series kinematics makes it easy for users of injection molding machines to unload at high speeds in a very compact space.

With the Epson standardised IMM (Injection Molding Machines) interfacing Euromap67 option, engineering time and costs are considerably reduced.

Quality inspection of the moulded part can also be easily integrated using EPSON CV2 vision systems.

All this and the unique programming platform, which includes many valuable options like the free of charge simulator makes N-Series the best in class within this segment.

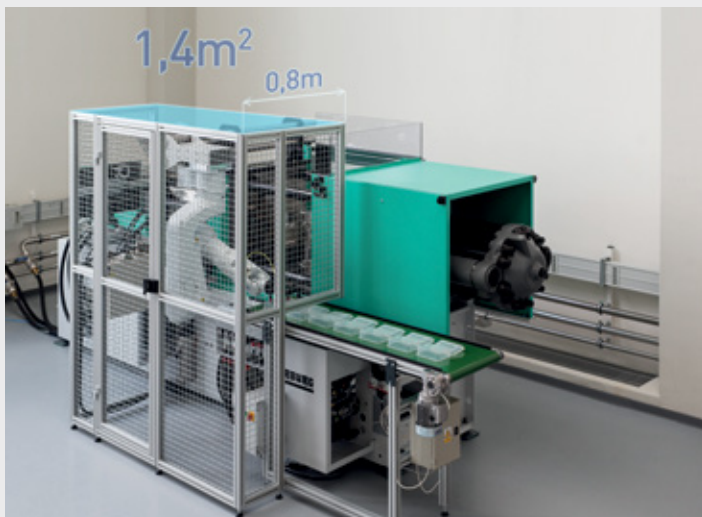

Machine: Injection Molding

Applications: machine tending, high speed unloading, quality inspection of the moulded part

Epson solution:

N6-A850 robot range: 850mm

Payload: 6kg

Euromap67 options board

CV2 vision system

Other integrated options – fieldbus interface solutions; RC+ 7.0 API software for open-platform functionality; teach pendants; and customisable GUIs

Simulation of robot cells

Good preparation is everything. Plan and visualise all procedures in your production process, validate your program offline initially and carry out troubleshooting and editing work without leaving your desk. With the Epson RC+ Simulator, which is included in the software package, you save time and money – throughout all phases.

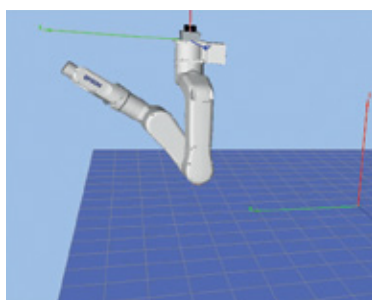

Phase 1 Design

You can plan your robot cell in full size in advance and assess the expected cycle time for your application. This verifies feasibility before a single part for the system has been produced.

System expansions can also be prepared in the simulation software to reduce down time.

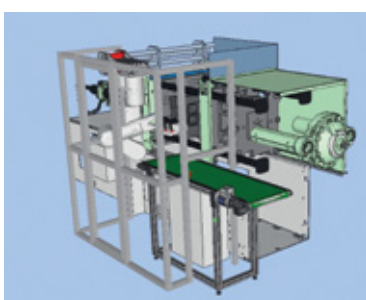

Phase 2 Integration

The programme validation process is completed offline before the robots are delivered. This enables you to create programmes in parallel – even complex motions can be displayed and evaluated.

Collision risks are thus identified and equipment damage prevented.

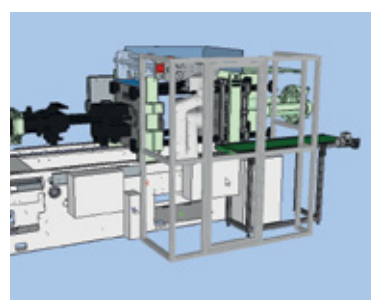

Phase 3 Operation and maintenance

Troubleshooting or programme modifications can be carried out conveniently from your desk.

Collision detection, reachability checks and robot motions can be visualised in a 3D layout.

Even simpler designs: Using the CAD-to-Point function

The CAD-to-Point function allows CAD data to be converted into robot points.

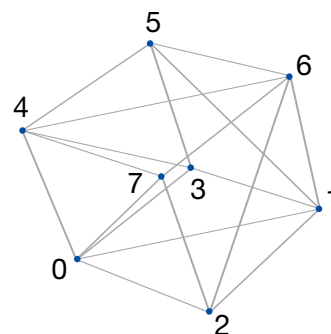

Integrated concept. Simple networking

The Epson RC700-A Controller is compact, economical and powerful. It communicates with fieldbus systems, and can also be connected to additional robots sensors, actuators, and conveyors.

**Smooth action
in force-guided
operations with
optional Epson
Force Sensing**



Teach Pendant TP3



Optional I/O cards

Optional Fieldbus, Digital
and Analog I/O cards.



Euromap67 Option

To provide interchangeability
between injection molding
machine and the handling robot.



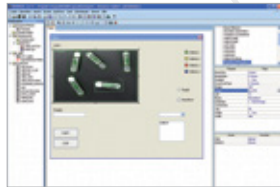

GUI development

Epson RC+ programming environment

RC+ Integrated Simulator.



Integrated image processing with Epson Compact Vision for

- Measurement
- Quality inspection
- Error detection
- Parts positioning
- Tracking on conveyors



The Vision feeder

To separate or singulate the parts for the robot to pick up.



High-speed conveyor tracking

Enables high-precision synchronisation with moving objects.

Technical specification

N-Series - N2-A450SR

Payload	2.5kg
Range	P point* 450mm max. 532.2mm
Repeatability	+/- 0.02mm
Permissible moment of inertia	J4 0.2kg.m ² J5 0.2kg.m ² J6 0.08kg.m ²
User cabling	Electrical D-Sub connector for 1 x 15-pin plug RJ45 connector for 1 x 8-pin plug (Ethernet) Connector for 1 x 8-pin plug (Force Sensor) Pneumatic Connectors for compressed air supply 2 x ø 6mm
Weight	19kg
Controller	RC700-A
Power source	AC200-240V Single phase
Mounting type	Table Top/Ceiling**
Installation	Environment Standard
Safety standard	CE mark, KCs mark

J1 = Axis 1 J4 = Axis 4

J2 = Axis 2 J5 = Axis 5

J3 = Axis 3 J6 = Axis 6

***P point**: intersection point of rotation centres of axes 4, 5 and 6

** To use the manipulators as "Ceiling mounting", need to change the model settings on RC+ software.

Package

Epson robot and control
Epson RC+ program DVD including simulation software
Mounting bracket for the robot control
3m motor and signal cable
3m motor cable for the robot control
Plug for emergency stop
Plug for standard inputs and outputs
Plug set for user cabling
Air connections (both straight and 90° angled)
Manuals on CD
Installation/safety manual
Bridging plug for the brake release unit

Manipulator options

Longer power and signal cable (5m/ 10m/ 15m/ 20m)
Brake release unit
Mounting bracket (floor)

Installation

The Epson N2-Series robots are usually mounted on the ceiling to take full advantage of their unique mobility and very small footprint. Depending on the application, a flexible floor mounting solution is also possible.

Side view

if $0^\circ \leq J2 \leq +180^\circ, -180^\circ \leq J3 \leq 0^\circ$

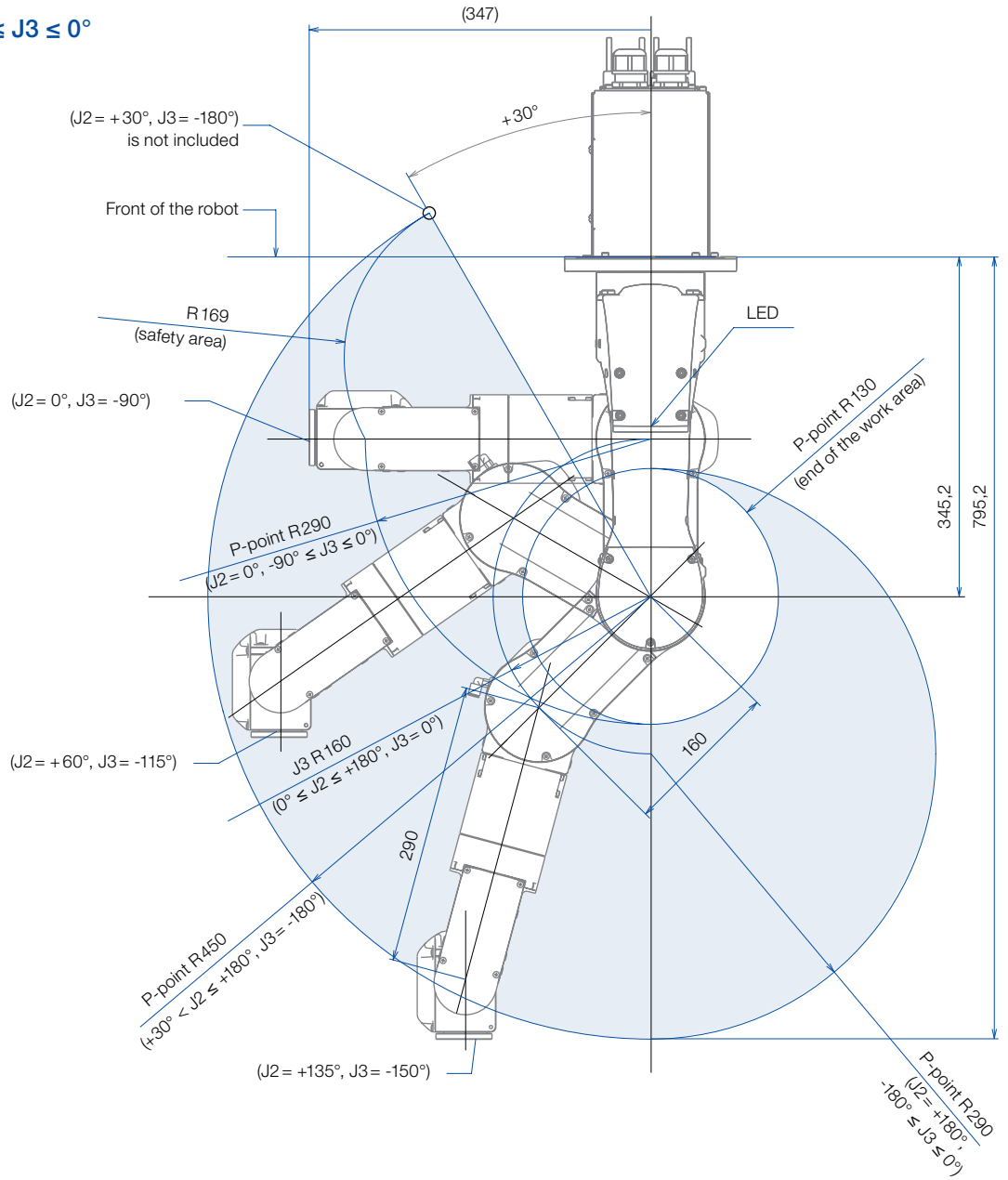

Top view

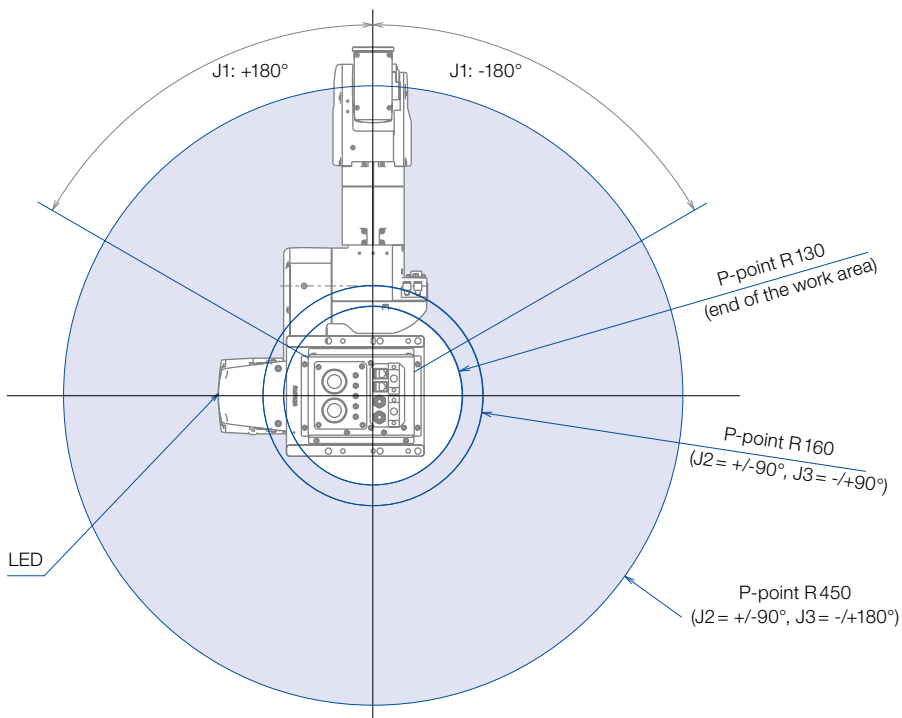

Flange

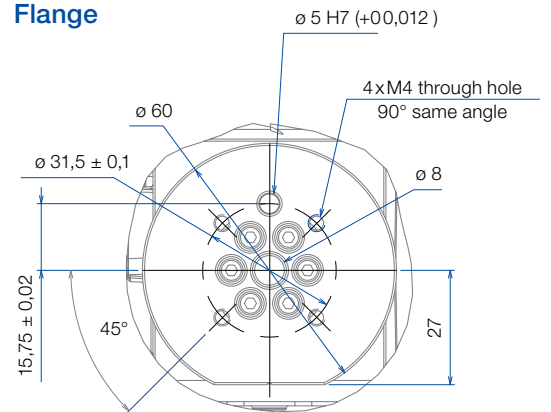

Technical specification

N-Series - N6-A850SR/SBR

Payload	6kg
Range	P point* 860mm max. 960mm
Repeatability	+/- 0.03mm
Permissible moment of inertia	J4 0.42kg.m ² J5 0.42kg.m ² J6 0.14kg.m ²
User cabling	Electrical D-Sub connector for 1 x 15-pin plug RJ45 connector for 1 x 8-pin plug (Ethernet) Connector for 1 x 8-pin plug (Force Sensor) Pneumatic Connectors for compressed air supply 2 x ø 6mm
Weight	64kg
Controller	RC700-A
Power source	AC200-240V Single phase
Mounting type	Ceiling
Installation	Standard Cleanroom class (option) ISO 5 & ESD
Safety Standard	CE mark, KCs mark

J1 = Axis 1 J4 = Axis 4

J2 = Axis 2 J5 = Axis 5

J3 = Axis 3 J6 = Axis 6

*P point: intersection point of rotation centres of axes 4, 5 and 6

Package

Epson robot and control
Epson RC+ program DVD including simulation software
Mounting bracket for the robot control
3m motor and signal cable
3m motor cable for the robot control
Plug for emergency stop
Plug for standard inputs and outputs
Plug set for user cabling
Air connections (both straight and 90° angled)
Manuals on CD
Installation/safety manual
Bridging plug for the brake release unit

Manipulator options

Longer power and signal cable (5 m/ 10m/ 15m/ 20m)
Brake release unit

Installation

The Epson N6-A850 series robots are optimised for ceiling mounting only to take full advantage of their unique mobility and very small footprint.

No table top mounting available

Top view

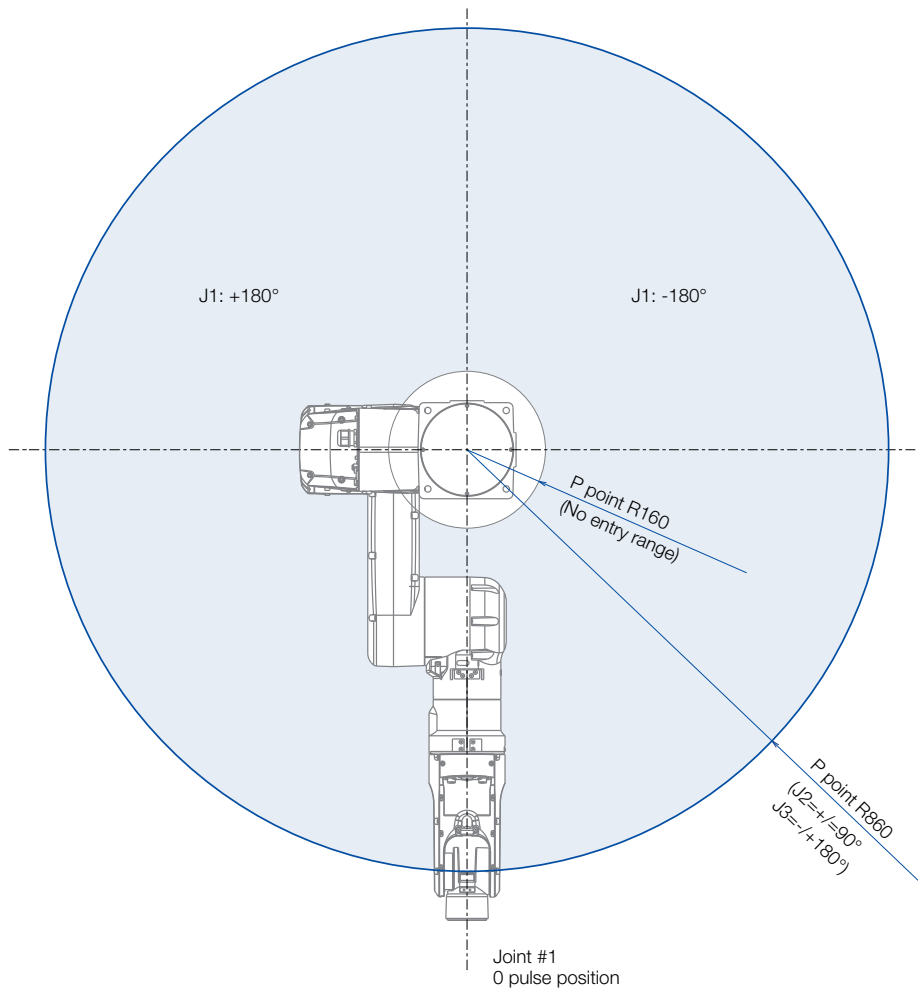

Lateral view

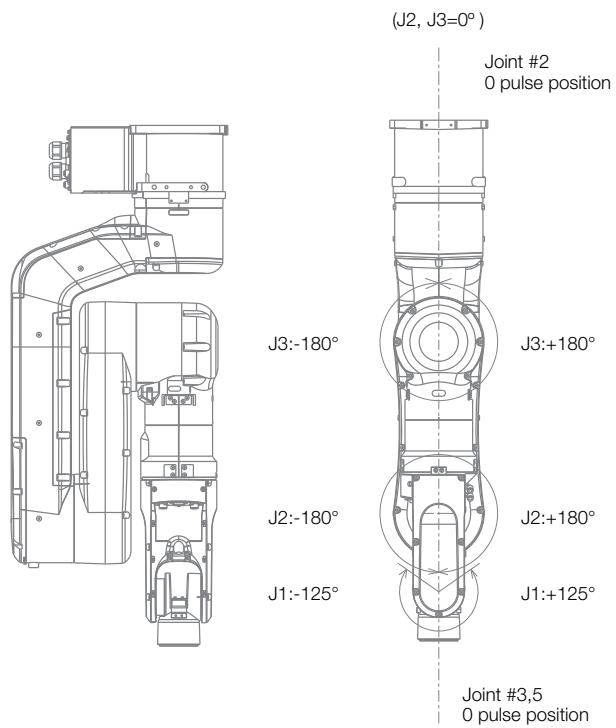

Side view (-180° ≤ J3 ≤ 0°)

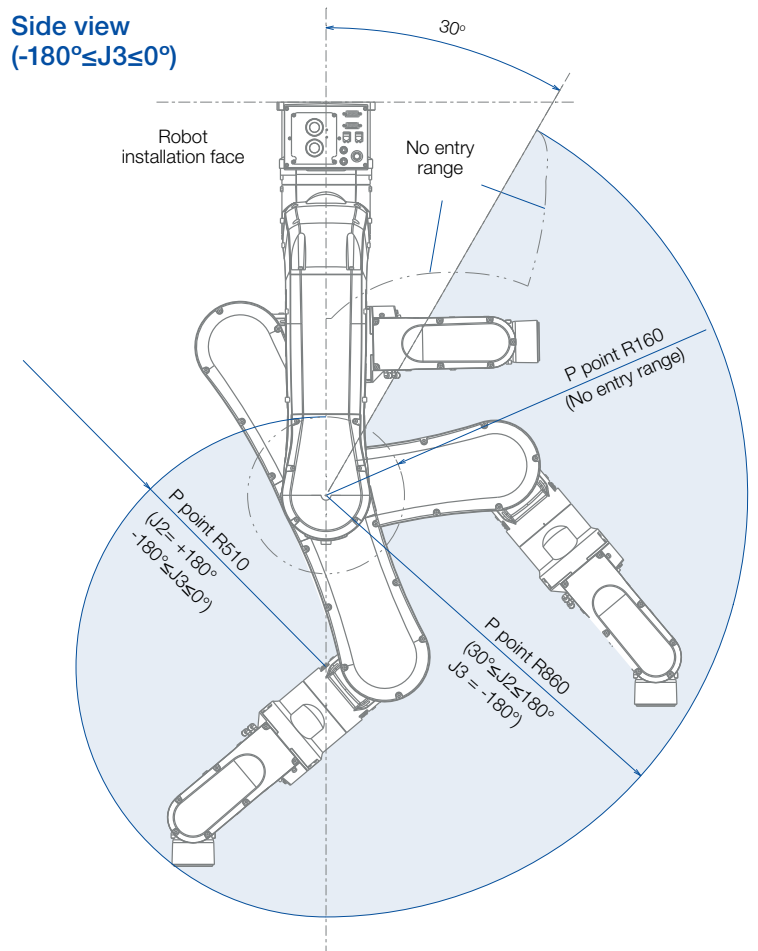

Technical specification

N-Series - N6-A1000S/SR/SB/SBR

Payload	6kg
Range	P point* 1010mm max. 1110mm
Repeatability	+/- 0.04mm
Permissible moment of inertia	J4 0.42kg.m ² J5 0.42kg.m ² J6 0.14kg.m ²
User cabling	Electrical D-Sub connector for 1 x 15-pin plug RJ45 connector for 1 x 8-pin plug (Ethernet) Connector for 1 x 8-pin plug (Force Sensor) Pneumatic Connectors for compressed air supply 2 x ø 6mm
Weight	69kg
Controller	RC700-A
Power source	AC200-240V Single phase
Mounting type	Table Top/Ceiling**
Installation	Standard Cleanroom class (option) ISO 5 & ESD
Safety Standard	CE mark, KCs mark

J1 = Axis 1 J4 = Axis 4

J2 = Axis 2 J5 = Axis 5

J3 = Axis 3 J6 = Axis 6

*P point: intersection point of rotation centres of axes 4, 5 and 6

** To use the manipulators as "Ceiling mounting", need to change the model settings on RC+ software.

Package

Epson robot and control
Epson RC+ program DVD including simulation software
Mounting bracket for the robot control
3m motor and signal cable
3m motor cable for the robot control
Plug for emergency stop
Plug for standard inputs and outputs
Plug set for user cabling
Air connections (both straight and 90° angled)
Manuals on CD
Installation/safety manual
Bridging plug for the brake release unit

Manipulator options

Longer power and signal cable (5 m/ 10m/ 15m/ 20m)
Brake release unit
Mounting bracket (floor)

Installation

The Epson N6-A1000 series robots are optimised for the floor mounting to offer more vertical motion efficiency to the factories, depending on the application, a flexible ceiling mounting solution is also possible.

Side view

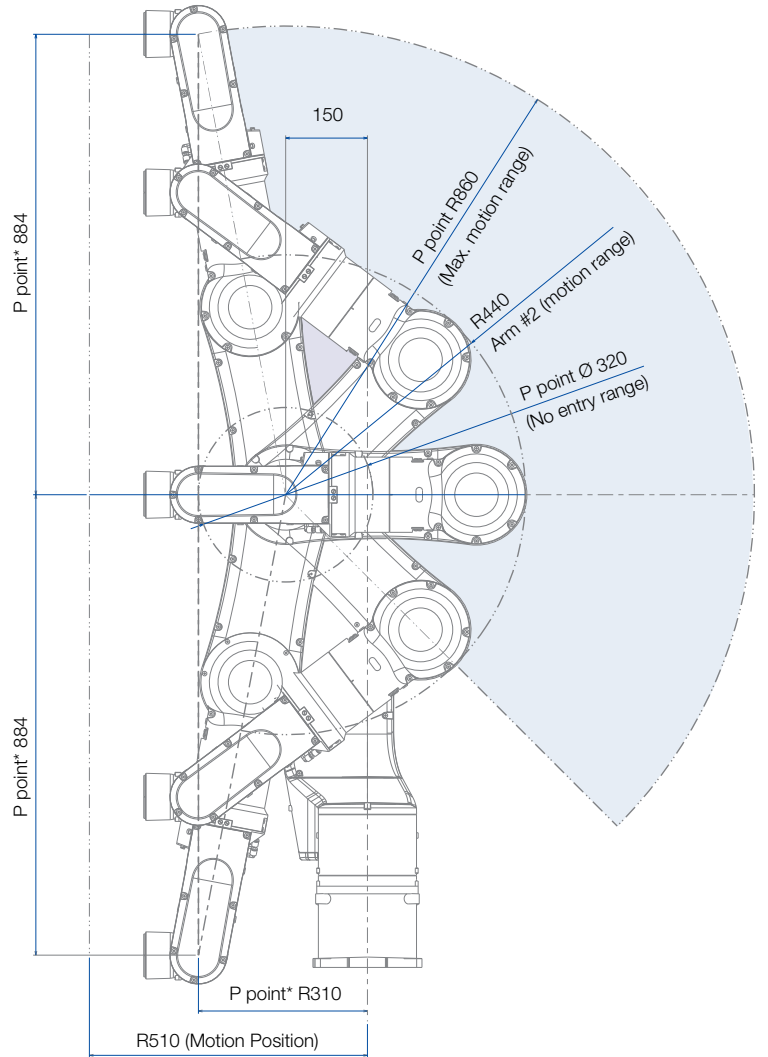

Top view

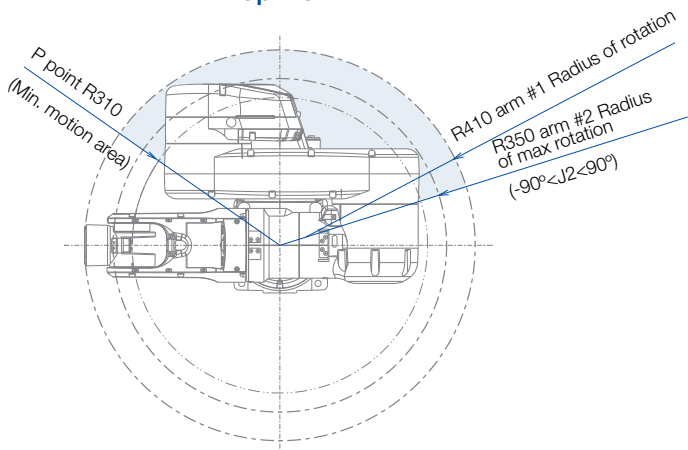

*When the P point is 310mm apart from the centre, upward and downward distance in CP motion will be the maximum

Lateral view

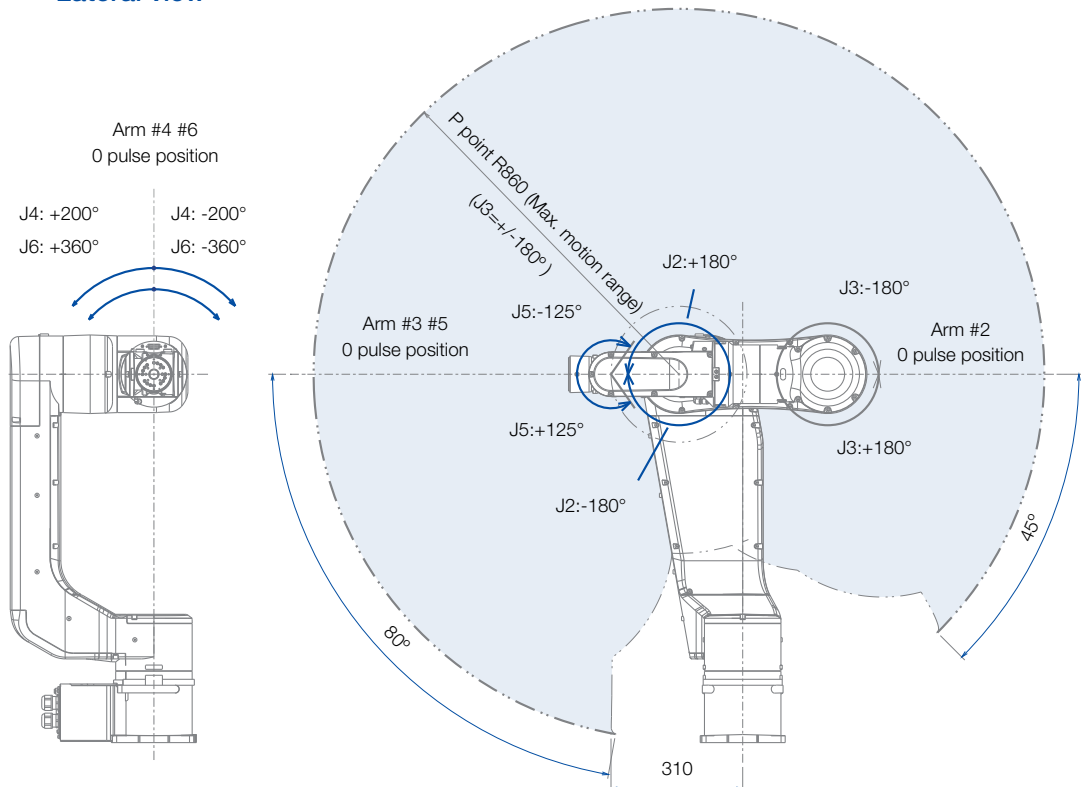

About Epson

Epson Robotic Solutions is one of the leading suppliers of high-tech robot systems that are renowned worldwide for their reliability. The product range includes six-axis, SCARA, entry-level LS-, T- and VT-series robots. Also, the special Epson-developed Spider and N-series robots, as well as the pioneering Dual Arm robot. Added to this are image processing controls and the Epson Force Sensor for force-controlled applications.

This gives Epson Robotic Solutions one of the most comprehensive ranges of high-precision industrial robots in the world, making them a technological pioneer for intelligently controlled automation processes.

Technological pioneer

- | | |
|---|---|
| 1982
Epson SCARA robots freely available in Japan for the first time | 2013
First application of Epson QMEMS® sensors in robotics, reducing 6-axis kinematics vibrations |
| 1986
First class 1 cleanroom robot | 2014
Epson Compact Vision CV2: Epson's own ultra-fast image processing computer |
| 1997
First PC-based controller | 2016
Epson N2 Series: World's first 6-axis robot with folding arm - extremely compact and space-saving |
| 2008
Inventor of the right or left arm-optimised G3 SCARA robot | 2017
Epson Dual Arm robot with an arm geometry inspired by human physiology, as well as integrated sensors such as cameras, force sensors, and accelerometers |
| 2009
Inventor of the spider – a unique SCARA robot with no dead zones | |

Pre and after-sales support

- Feasibility studies for maximum planning and project security
- Support for planning and implementation
- Introductory seminars, programming/maintenance courses, operator training
- Inspection and individual maintenance concepts
- Hotline service, on-site repair service
- Central spare part stocking

Epson Industrial Solutions Centre – find your solution

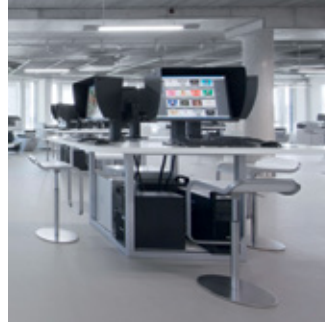

Experience all our Epson robots in action. Build, simulate and improve your automation application in a workshop cell, with help from our experts. The cell can be controlled and networked using all conventional fieldbus systems. In addition, we can supply you with modern peripherals such as a vision and conveyor tracking system.

Make an appointment

Call us on
+49 2159 538 1800

or send an email to
info.rs@epson.de

Epson Deutschland GmbH
Robotic Solutions
Otto-Hahn-Strasse 4
40670 Meerbusch

Phone: **+49 2159 5381800**
Fax: **+49 2159 5383170**
E-mail: **info.rs@epson.de**
www.epson.de/robots



Committed to corporate and social responsibility

Epson is committed to developing environmentally conscious products, which means that sustainability is considered from conception to completion. We help customers recognise the environmental gains brought on by technology, whether it is redefining manufacturing through innovative robotics, saving energy with our office printing technology or revolutionising textile printing with digital solutions.

We are committed to all 17 United Nations' sustainable development goals and to the aims of the circular economy. We offer sustainable innovations because we recognise that the choices we make as organisations, individuals or a society will be essential to our shared success.

The content of this publication has not been approved by the United Nations and does not reflect the views of the United Nations or its officials or Member States www.un.org/sustainabledevelopment



Epson America Inc.
www.epsonrobots.com

Seiko Epson Corp
<http://global.epson.com/products/robots/>

Epson China Co, Ltd.
www.epson.com.cn/robots/

For further information please contact your local Epson office or visit www.epson-europe.com

Algeria (+2213) 770 938 617 **Austria** 01 253 49 78 333 **Belgium** +32 (0)2 792 04 47 **Czech** 800/142 052 **Denmark** 44 50 85 85 **East Africa** (+254) 734 354 075
Finland 0201 552 091 **France** 09 74 75 04 04 (Cost of local call, operator charges may apply) **Germany** +49 (0) 2159/92 79 500 **Greece** (0030) 211 198 62 12
Hungary 06800 147 83 **Ireland** 01 436 7742 **Israel** (+972)-3-5751833 **Italy** 02-660321 10 (0,12 €/min) **Luxembourg** +352 27860692 **Middle East** +9714 2677638
Morocco (+212) 661 31 11 18 **Netherlands** +31 (0)20 708 5099 **Norway** +47 67 11 37 00 **Poland** 0-0-800 4911299 (0,16 zł/min) **Portugal** 707 222 111
Romania 0040 214025024 **Russia** (095) 777-03-55 **Slovakia** 0850 111 429 **Southern Africa** (+2711) 465-9621 **Spain** 93 582 15 00 **Sweden** 0771-400135
(Mobilsamtal – 0,99 kr/min, Lokala samtal – 0,30 kr/min, Utlandssamtal – 0,89 kr/min) **Switzerland** 022 592 7923 **Tunisia** (+216) 9833 3571 **Turkey** (0212) 3360303
United Kingdom 0871 42 37766 (+10p per minute plus network extras) **West Africa** (+234)8020727843

Trademarks and registered trademarks are the property of Seiko Epson Corporation or their respective owners.
Product information is subject to change without prior notice.

EPSON®