

ProSix C4 and C8 series

Efficiency and
precision you
can rely on



EPSON®
EXCEED YOUR VISION

A robot for every application

Introducing the Epson ProSix series: six-axis robots with the range and load capacity for every application – and precision as standard. With five robots in the range, you'll find one perfectly suited to your needs.

Whatever your industry, the Epson ProSix C4 and C8 six-axis robots are equal to the challenge. Marked out by their slim, compact design, they can work with maximum precision even at high speeds, thanks to our QMEMS® sensor technology.

ProSix C4 series – with 4kg payload



Epson ProSix C4

Range: 600mm

Applications include: identification, assembly, soldering and welding, measurement, testing and inspection.



Epson ProSix C4L

Range: 900mm

Applications include: machine loading and unloading, packing and order picking, assembly, soldering and welding, palletising.

Epson ProSix C4 and C8 series

With a variety of load capacity and different ranges, the series is exceptionally versatile. The robots can be put to use in all kinds of sectors and industries including: automotive, electronics, machine tools, medical devices, semiconductor, foodstuffs, and plastics and metal.

ProSix C8 series – with 8kg payload



Epson ProSix C8

Range: 710mm
Applications include: identification, packaging and order picking, assembly, soldering and welding, measurement, testing and inspection.



Epson ProSix C8L

Range: 900mm
Applications include: machine loading and unloading, identification, packaging and order picking, assembly, soldering and welding, palletising.

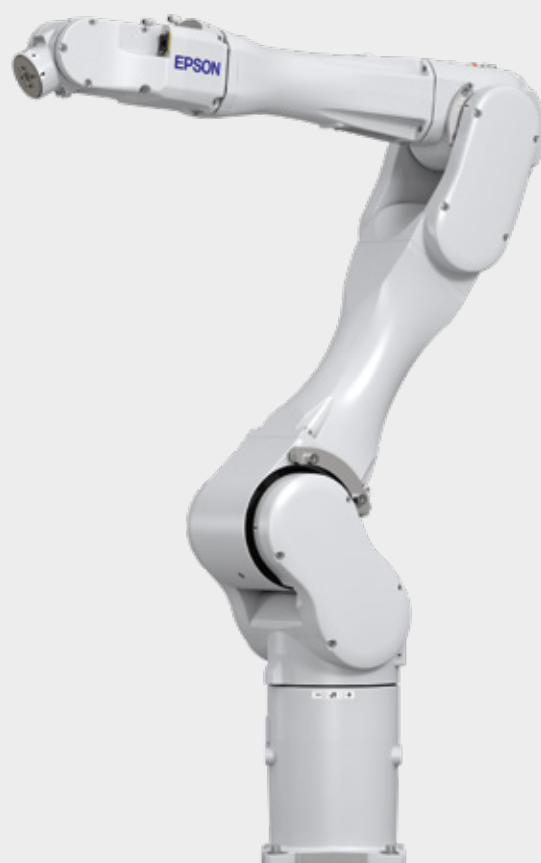

Epson ProSix C8XL

Range: 1,400mm
Applications include: machine loading and unloading, parts picking, packaging and order picking, soldering and welding, palletising.

Efficiency redefined: C4 and C8

Fast, sleek, precise

If you're looking for a robot that can work in confined spaces, often in conjunction with other robots, and is accurate even when time is short, you're looking in the right place.

The Epson ProSix series C4 and C8 can help your system reach its full potential. The six-axis machines work at high speeds with precise path behaviour, all in an ultra-slim body. The variety of assembly options gives you all the flexibility you need.

Impressive team player

You can easily combine your Epson six-axis robot with other members of the family, such as SCARA robots, the Epson Spider and other peripheral devices. Although they perform different tasks, robots speak one language via Epson's RC700-A controller: Epson RC+.

Strong and silent

Epson QMEMS® sensor technology and Epson Smart Motion Motor Management.

These fast, powerful, six-axis robots features revolutionary Motor Management from Epson and, for the first time, QMEMS® technology, which uses high-precision motion sensors.

QMEMS®-equipped robots enable exceptionally quiet and vibration-free travel, even under load and at high speeds. The benefit of this is improved production throughput and consistently stable quality in all assembly tasks.



One for all: Epson RC700-A controller

Extremely compact, outstandingly economical and powerful, the Epson RC700-A controller can communicate with fieldbus systems and can also be used to connect additional robots sensors, actuators and conveyors.

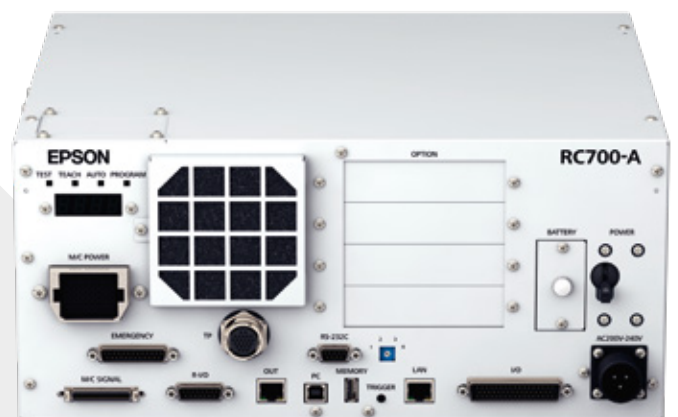



Saves space and reduces cycle times thanks to the possibilities for the axes 2 and 3 to rollover.



Increased freedom of movement thanks to special joint geometry, which enables axis five to rotate at a $\pm 135^\circ$ angle. Fewer interference contours, slim design, internal supply lines for maximum system reliability, simple commissioning and reduced maintenance costs.

Give your robots a clear view with Epson Compact Vision integrated image processing

Accelerate production processes, keep errors to a minimum and reduce of costs – Epson's integrated image processing handles even the most demanding applications.

Single source kinematics, controller and image processing

The Epson Vision Guide 7.0 software is integrated with the Epson RC+ development environment resulting in quicker set-up and vision sequences that can be created in just a few clicks.

Programming uses simple drag and drop with no need for additional editors. Robot controller and test tasks/positioning are interlinked with no interface problems. What's more, robots and image processing communicate with each other in milliseconds. The Epson image processing supports high-resolution cameras and colour cameras.

Compact Vision from Epson, ideal for:

Measurement

Quality inspection and error detection

Parts positioning, even for manufacturing variations and varying locations

Complex product tracking on conveyor

The Epson image processing is available in various versions

Everything in range, everything in view:

Convenient mobile operating and display unit

Teach pendant TP3

The mobile terminal has an ergonomic, flat housing with a brilliant and high contrast 10" TFT LCD display. Fast processors allow for sophisticated visualisation and operating applications.



Epson ProSix C4

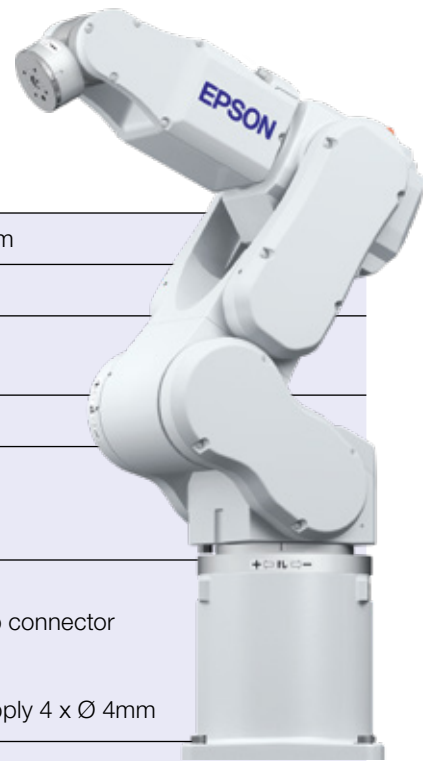

	C4-A601S
Design	Vertical articulated arm
Load capacity	4/5*kg
Range	P point** 600mm max. 665mm
Repeatability	+/-0,02mm
Permissible moment of inertia	J4 0.15 kg * m ² J5 0.15 kg * m ² J6 0.10 kg * m ²
User cabling	Electrical Connection for 1 x 9-pin D-Sub connector Pneumatic Connectors for compressed air supply 4 x Ø 4mm
Weight	27kg
Controllers	RC700-A, RC700DU-A
Installation	Floor/ceiling each also recessed
Ambient condition	Cleanroom class (option) ISO3 & ESD Protection class IP40

J1 = Axis 1
J2 = Axis 2
J3 = Axis 3

J4 = Axis 4
J5 = Axis 5
J6 = Axis 6

* **Possible under specific conditions**
(see manual)

** **P point:** Intersection point of rotation centres of axes 4, 5 and 6

Package

Epson robots and controller
Epson RC+ program CD including simulation software
2x mounting bracket sets for the robot controller
3m power and signal cable
3m power cable for the robot controller
Emergency stop plug
Plug for standard inputs and outputs
Plug set for user cabling
2x air connection sets (each with 4x straight and 4x 90° angled)
CD manuals
Installation/safety manual

Manipulator options

Extended power and signal cable (5m / 10m / 20m)
Brake release unit
Mounting bracket

Installation

The Epson ProSix C4 and ProSix C4L six-axis robots have flexible installation options which work for a wide range of applications.

In addition to floor and ceiling installation, recessed installation is also possible. In this case the base of the robot is not required and the cable conduit is hidden, allowing you to reduce the height of your production cell.

Side view

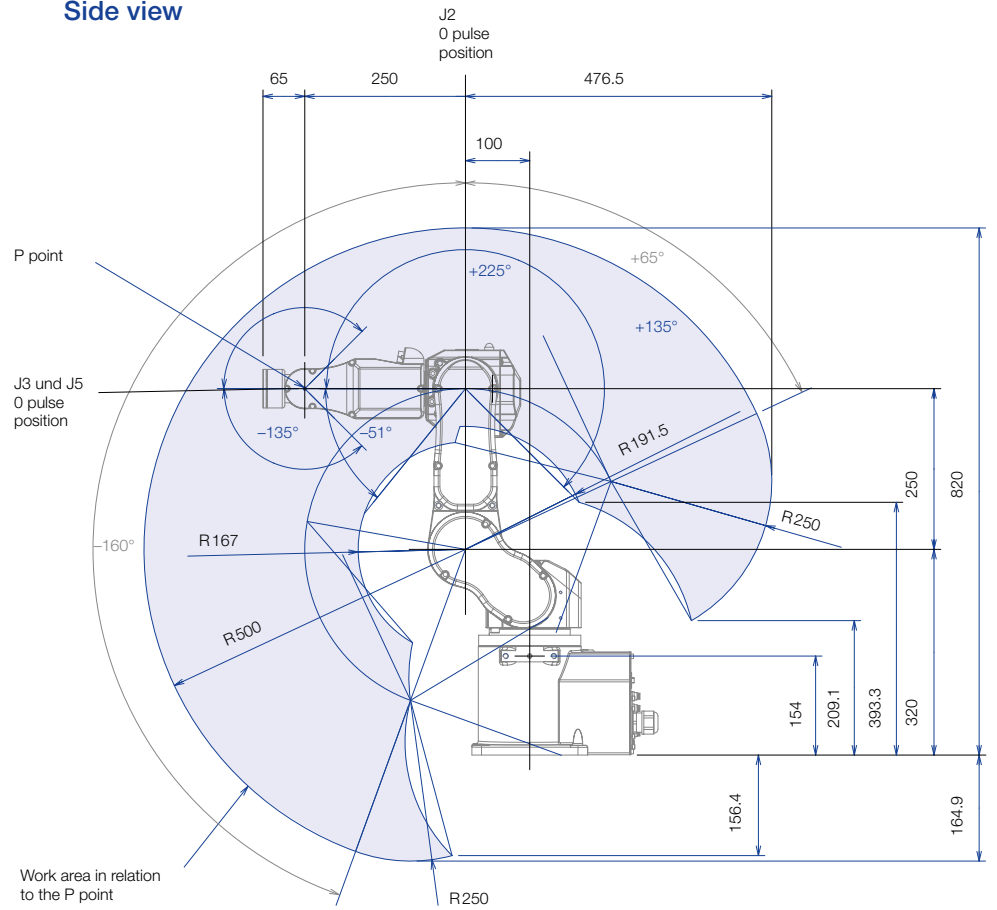

Flange

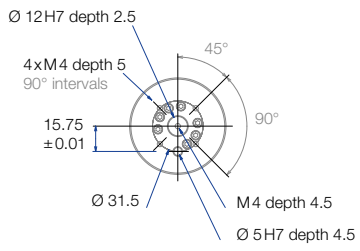

Front view

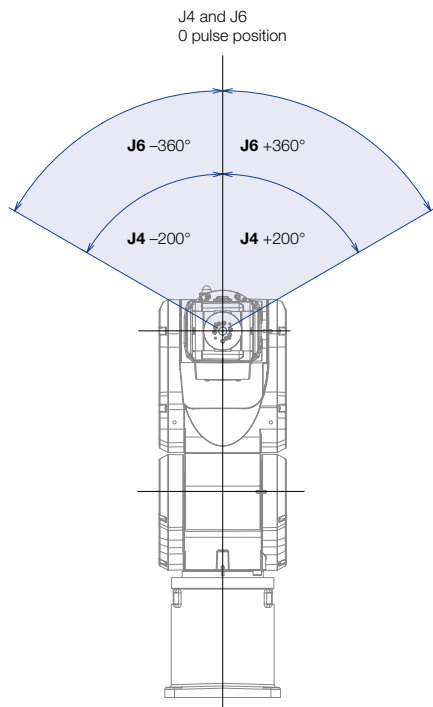

Top view

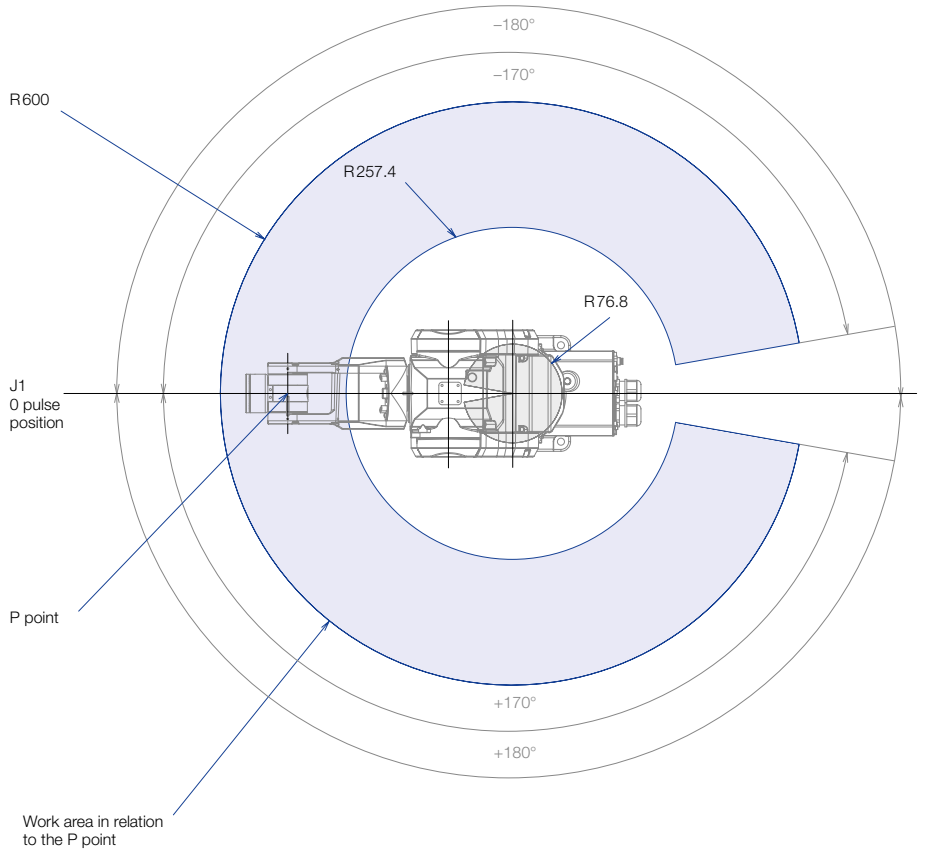

Epson ProSix C4L

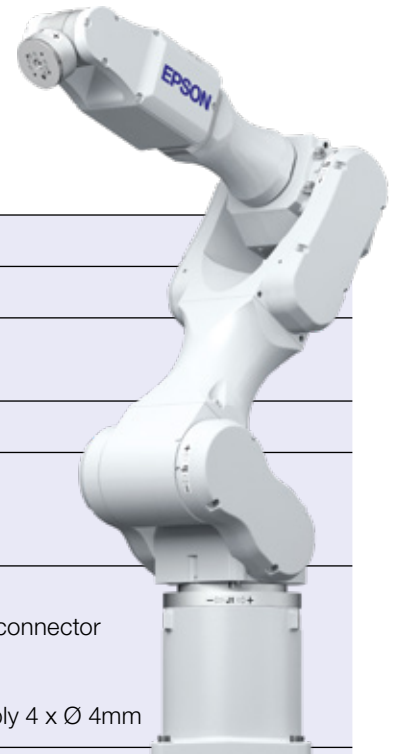

	C4-A901S
Design	Vertical articulated arm
Load capacity	4/5*kg
Range	P point** 900mm max. 965mm
Repeatability	+/-0,03mm
Permissible moment of inertia	J4 0.15 kg * m ² J5 0.15 kg * m ² J6 0.10 kg * m ²
User cabling	Electrical Connection for 1 x 9-pin D-Sub connector Pneumatic Connectors for compressed air supply 4 x Ø 4mm
Weight	29kg
Controllers	RC700-A, RC700DU-A
Installation	Floor/ceiling each also recessed
Ambient condition	Cleanroom class (option) ISO3 & ESD Protection class IP40

J1 = Axis 1
J2 = Axis 2
J3 = Axis 3

J4 = Axis 4
J5 = Axis 5
J6 = Axis 6

* **Possible under specific conditions**
(see manual)

** **P point:** Intersection point of rotation centres of axes 4, 5 and 6

Package

Epson robots and controller
Epson RC+ program CD including simulation software
2x mounting bracket sets for the robot controller
3m motor and signal cable
3m motor cable for the robot controller
Emergency stop plug
Plug for standard inputs and outputs
Plug set for user cabling
2x air connection sets (each with 4x straight and 4x 90° angled)
Manuals on CD
Installation/safety manual

Manipulator options

Extended power and signal cable (5m / 10m / 20m)
Brake release unit
Mounting bracket

Installation

The Epson ProSix C4 and ProSix C4L six-axis robots have flexible installation options that work for a wide range of applications.

In addition to floor and ceiling installation, recessed installation is also possible. In this case the base of the robot is not required and the cable conduit is hidden, allowing you to reduce the height of your production cell.

Side view

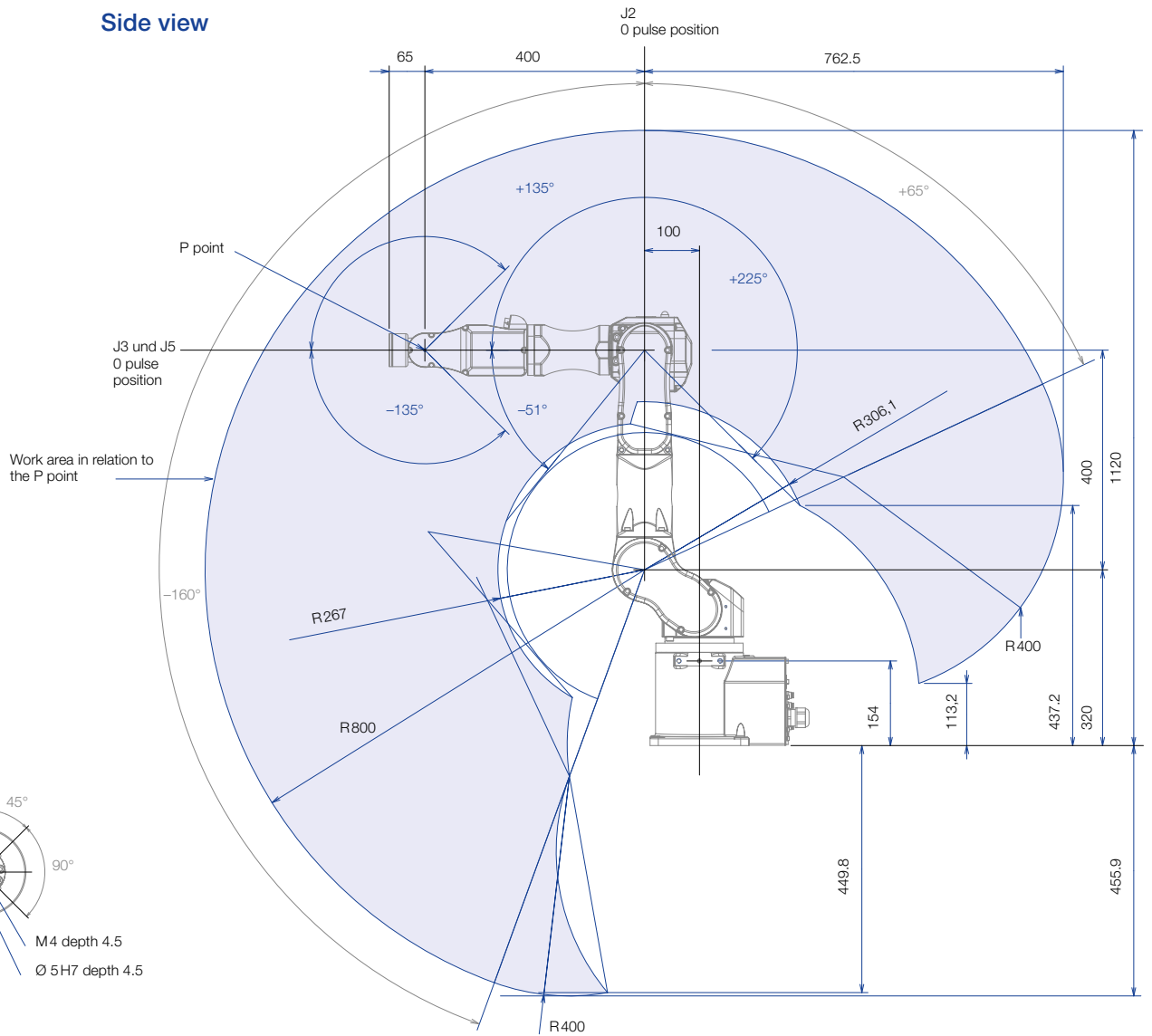

Flange

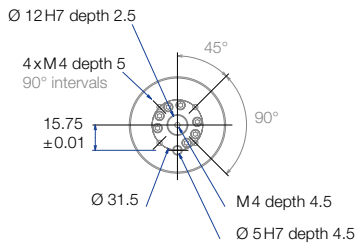

Front view

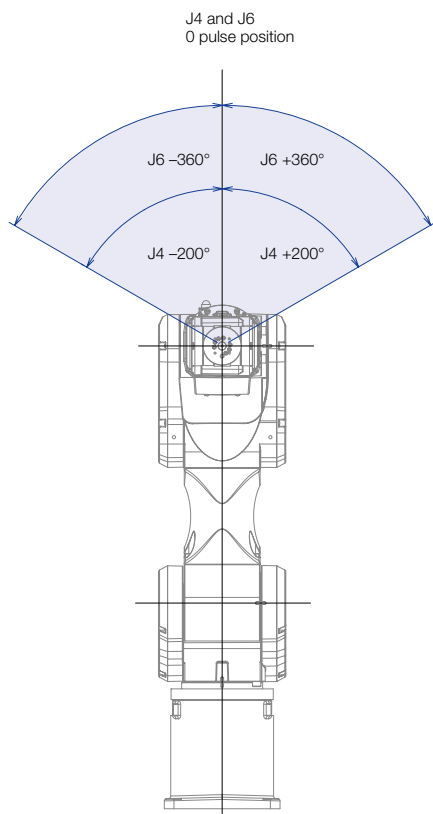

Top view

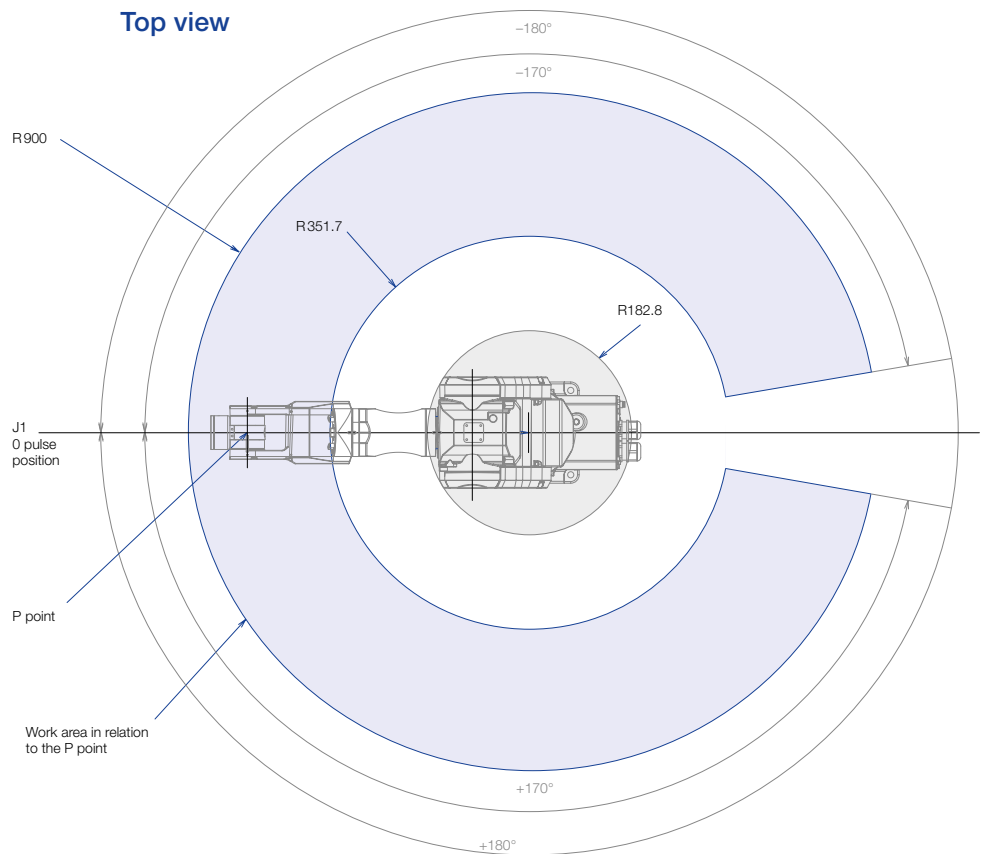

Epson ProSix C8

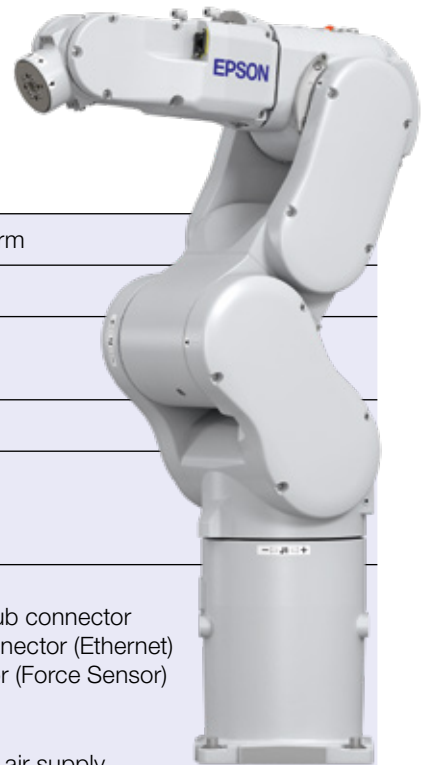

	C8-A701S
Design	Vertical articulated arm
Load capacity	8kg
Range	P point* 710mm max. 790mm
Repeatability	+/-0.02mm
Permissible moment of inertia	J4 0.47 kg * m ² J5 0.47 kg * m ² J6 0.15 kg * m ²
User cabling	<p>Electrical Connection for 1 x 15-pin D-Sub connector Connection for 1 x 8-pin RJ45-connector (Ethernet) Connection for 1 x 8-pin connector (Force Sensor)</p> <p>Pneumatic Connectors for compressed air supply 2 x Ø 6mm</p>
Weight	49kg (IP67: 53kg)
Controllers	RC700-A, RC700DU-A
Installation	Floor/ceiling
Ambient condition	<p>Cleanroom class (option) ISO3 & ESD</p> <p>Protection class IP 40 (standard)/IP67 (option)</p>

J1 = Axis 1
J2 = Axis 2
J3 = Axis 3

J4 = Axis 4
J5 = Axis 5
J6 = Axis 6

* **P point:** Intersection point of rotation centres of axes 4, 5 and 6

Package

Epson robots and controller
Epson RC+ program CD including simulation software
x2 mounting bracket sets for the robot controller
3m power and signal cable
3m power cable for the robot controller
Emergency stop plug
Plug for standard inputs/outputs
Plug set for user cabling
x2 air connection sets (each with 2x straight and 2x 90° angled)
CD manuals
Installation/safety manual

Manipulator options

Extended power and signal cable (5m / 10m / 20m)
Brake release unit

Installation

The Epson ProSix C8, ProSix C8L and ProSix C8XL six-axis robots have flexible installation options, including floor and ceiling installation, which suit a wide range of applications.

Flange

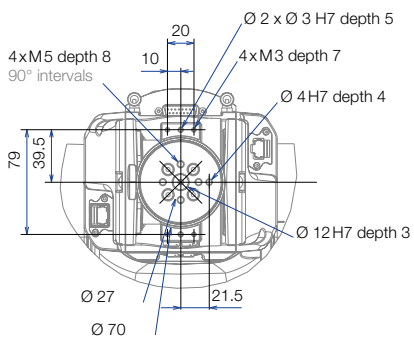

Side view

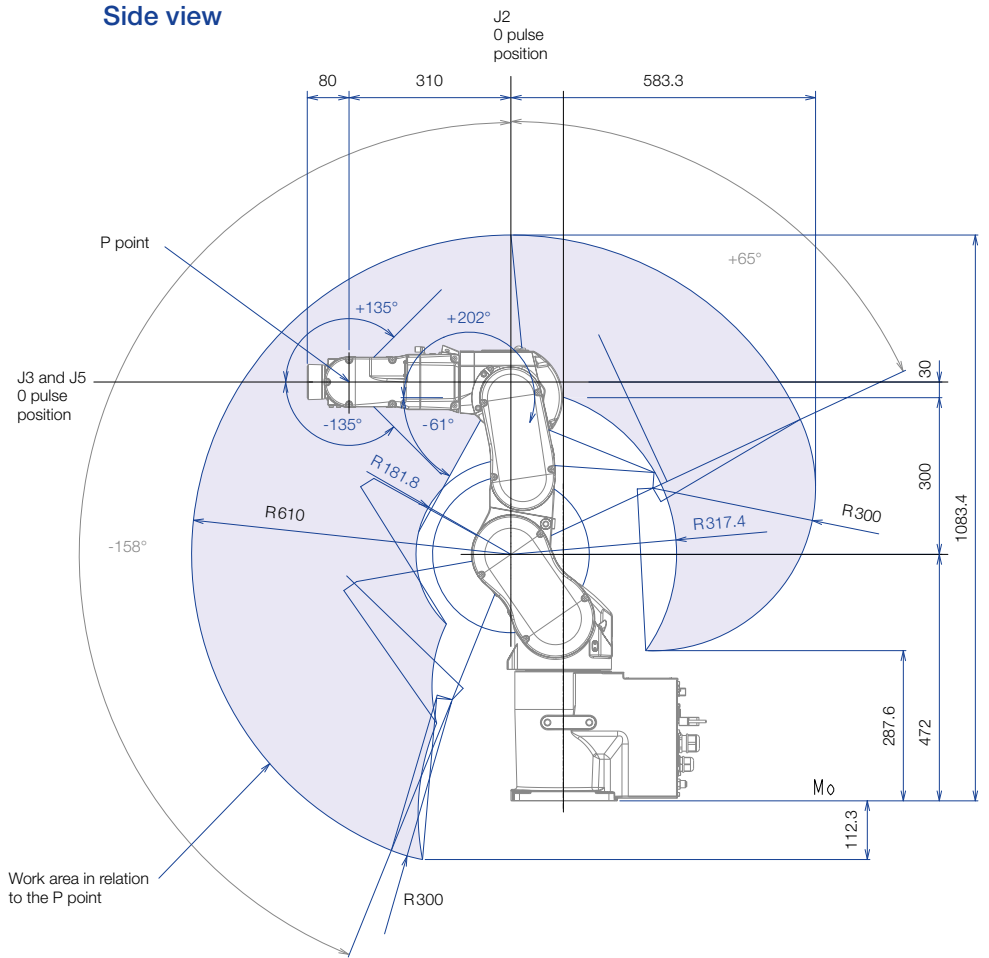

Front view

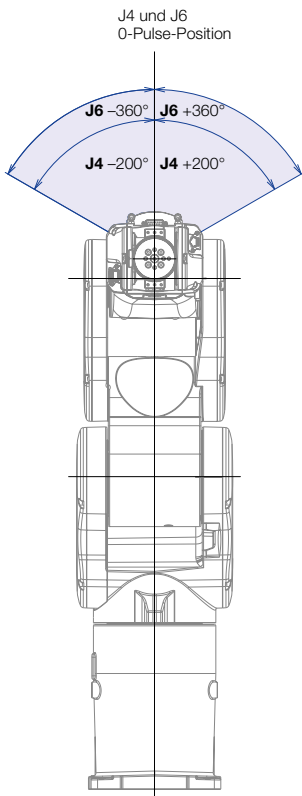

Top view

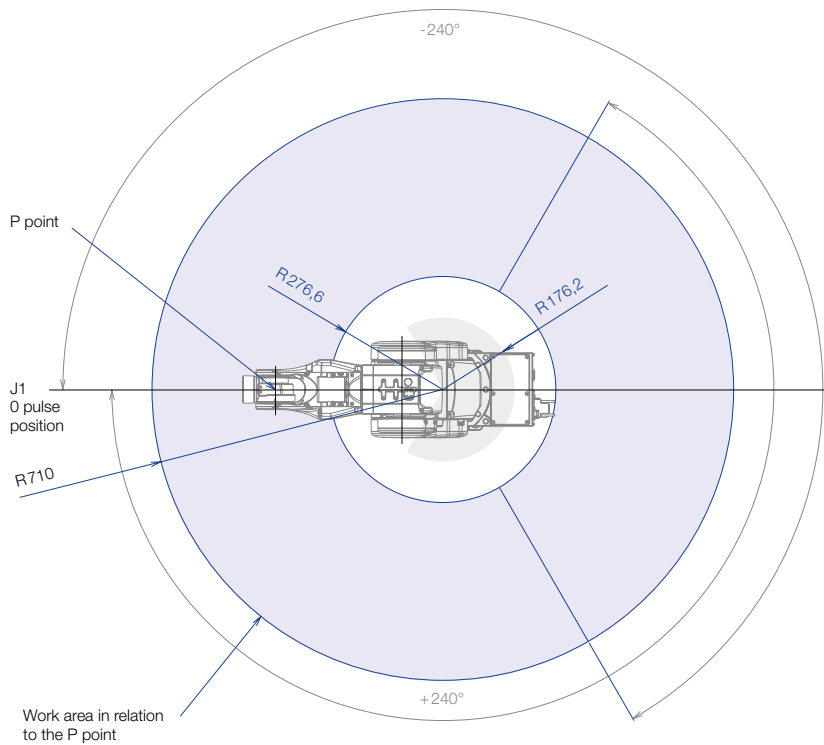

Epson ProSix C8L

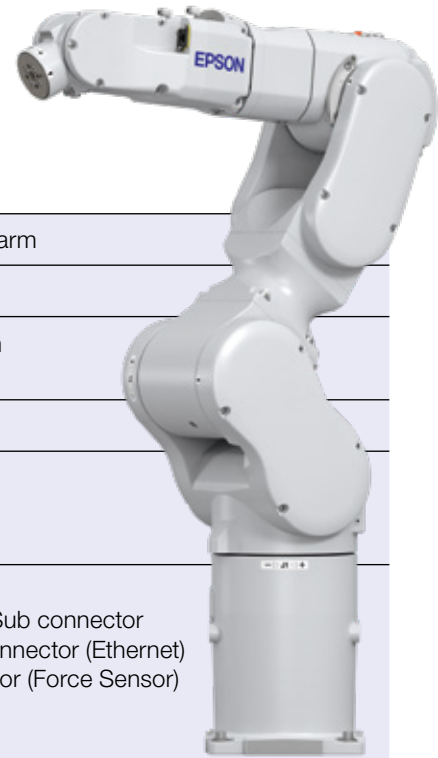

	C8-A901S
Design	Vertical articulated arm
Load capacity	8kg
Range	P point* 900mm max. 980mm
Repeatability	+/-0,03mm
Permissible moment of inertia	J4 0.47 kg * m ² J5 0.47 kg * m ² J6 0.15 kg * m ²
User cabling	<p>Electrical Connection for 1 x 15-pin D-Sub connector Connection for 1 x 8-pin RJ45-connector (Ethernet) Connection for 1 x 8-pin connector (Force Sensor)</p> <p>Pneumatic Connectors for compressed air supply 2 x Ø 6mm</p>
Weight	52 kg (IP67: 56 kg)
Controllers	RC700-A, RC700DU-A
Installation	Floor/ceiling
Ambient condition	<p>Cleanroom class (option) ISO3 & ESD</p> <p>Protection class IP40 (standard)/IP67 (option)</p>

J1 = Axis 1
J2 = Axis 2
J3 = Axis 3

J4 = Axis 4
J5 = Axis 5
J6 = Axis 6

* **P point:** Intersection point of rotation centres of axes 4, 5 and 6

Package

Epson robots and controller
Epson RC+ program CD including simulation software
2x mounting bracket sets for the robot controller
3m motor and signal cable
3m motor cable for the robot controller
Emergency stop plug
Plug for standard inputs/outputs
Plug set for user cabling
2x air connection sets (each with 2x straight and 2x 90° angled)
CD manuals

Manipulator options

Extended power and signal cable (5m / 10m / 20m)
Brake release unit

Installation

The Epson ProSix C8, ProSix C8L and ProSix C8XL six-axis robots have flexible installation options, including floor and ceiling installation, which suit a wide range of applications.

Side view

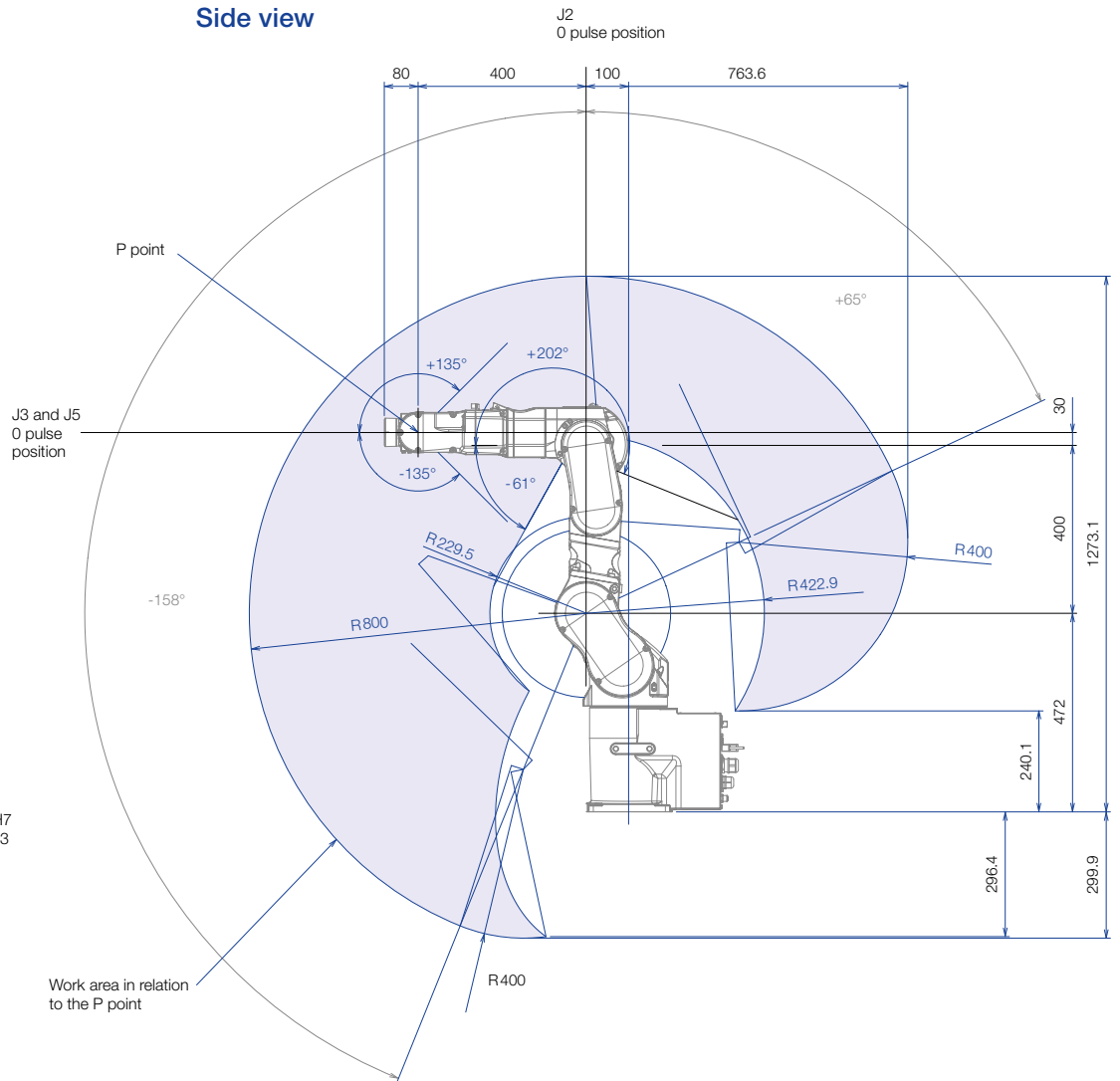

Flange

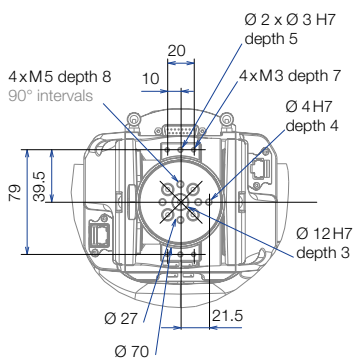

Front view

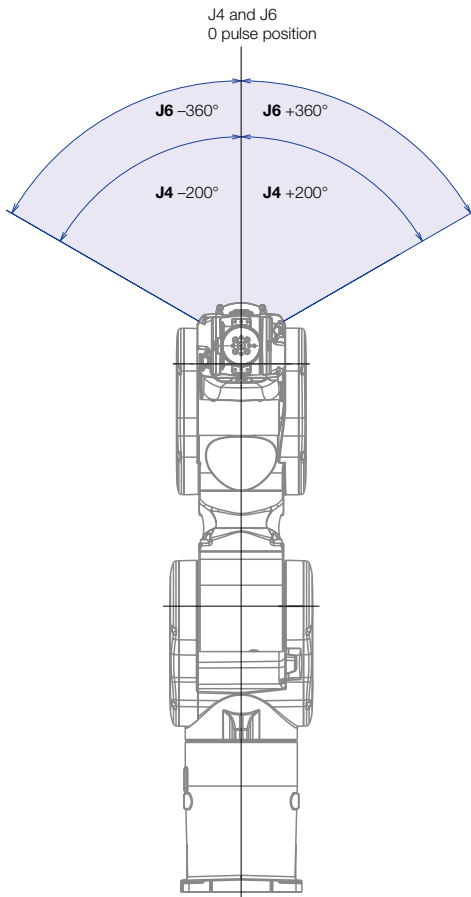

Top view

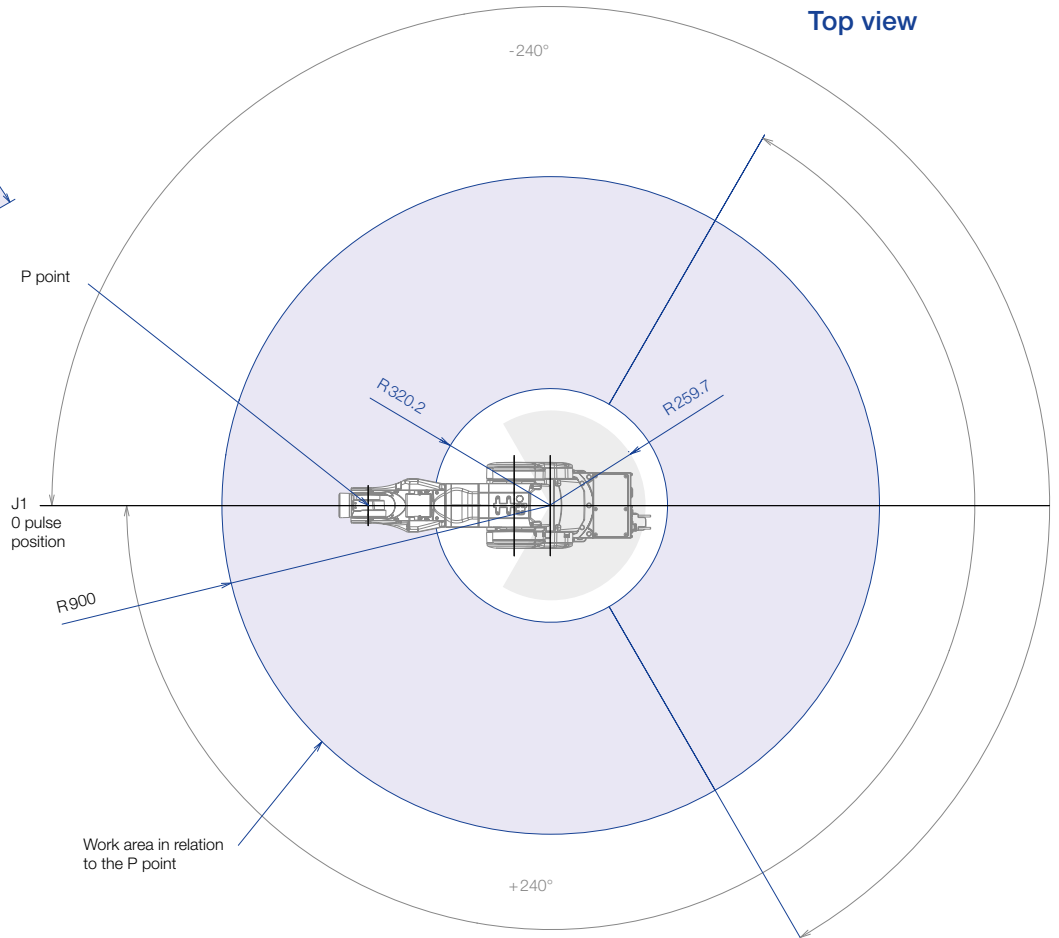

Epson ProSix C8XL

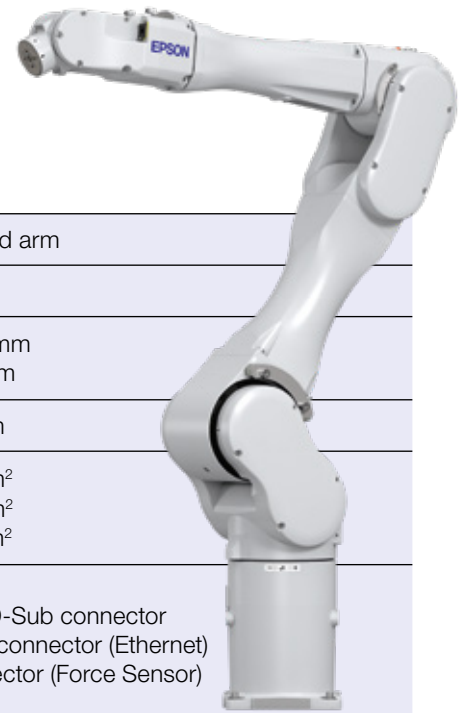

	C8-A1401S
Design	Vertical articulated arm
Load capacity	8kg
Range	P point* 1400mm max. 1480mm
Repeatability	+/-0.05mm
Permissible moment of inertia	J4 0.47 kg * m ² J5 0.47 kg * m ² J6 0.15 kg * m ²
User cabling	<p>Electrical Connection for 1 x 15-pin D-Sub connector Connection for 1 x 8-pin RJ45-connector (Ethernet) Connection for 1 x 8-pin connector (Force Sensor)</p> <p>Pneumatic Connectors for compressed air supply 2 x Ø 6mm</p>
Weight	62 kg (IP67: 66 kg)
Controllers	RC700-A, RC700DU-A
Installation	Floor/ceiling
Ambient condition	<p>Cleanroom class (option) ISO3 & ESD</p> <p>Protection class IP40 (standard)/IP67 (option)</p>

J1 = Axis 1
J2 = Axis 2
J3 = Axis 3

J4 = Axis 4
J5 = Axis 5
J6 = Axis 6

* **P point:** Intersection point of rotation centres of axes 4, 5 and 6

Package

Epson robots and controller
 Epson RC+ program CD including simulation software
 2 mounting bracket sets for the robot controller
 3m power and signal cable
 3m power cable for the robot controller
 Emergency stop plug
 Plug for standard inputs/outputs
 Plug set for user cabling
 2 air connection sets (each with 2 x straight and 2 x 90° angled)
 CD manuals
 Installation/safety manual

Manipulator options

Extended power and signal cable (5m/10m/20m)
 Brake release unit

Installation

The Epson ProSix C8, ProSix C8L and ProSix C8XL six-axis robots have flexible installation options, including floor and ceiling installation, which suit a wide range of applications.

Flange

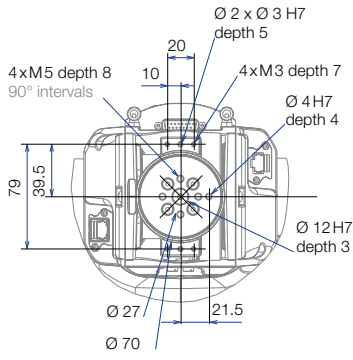

Side view

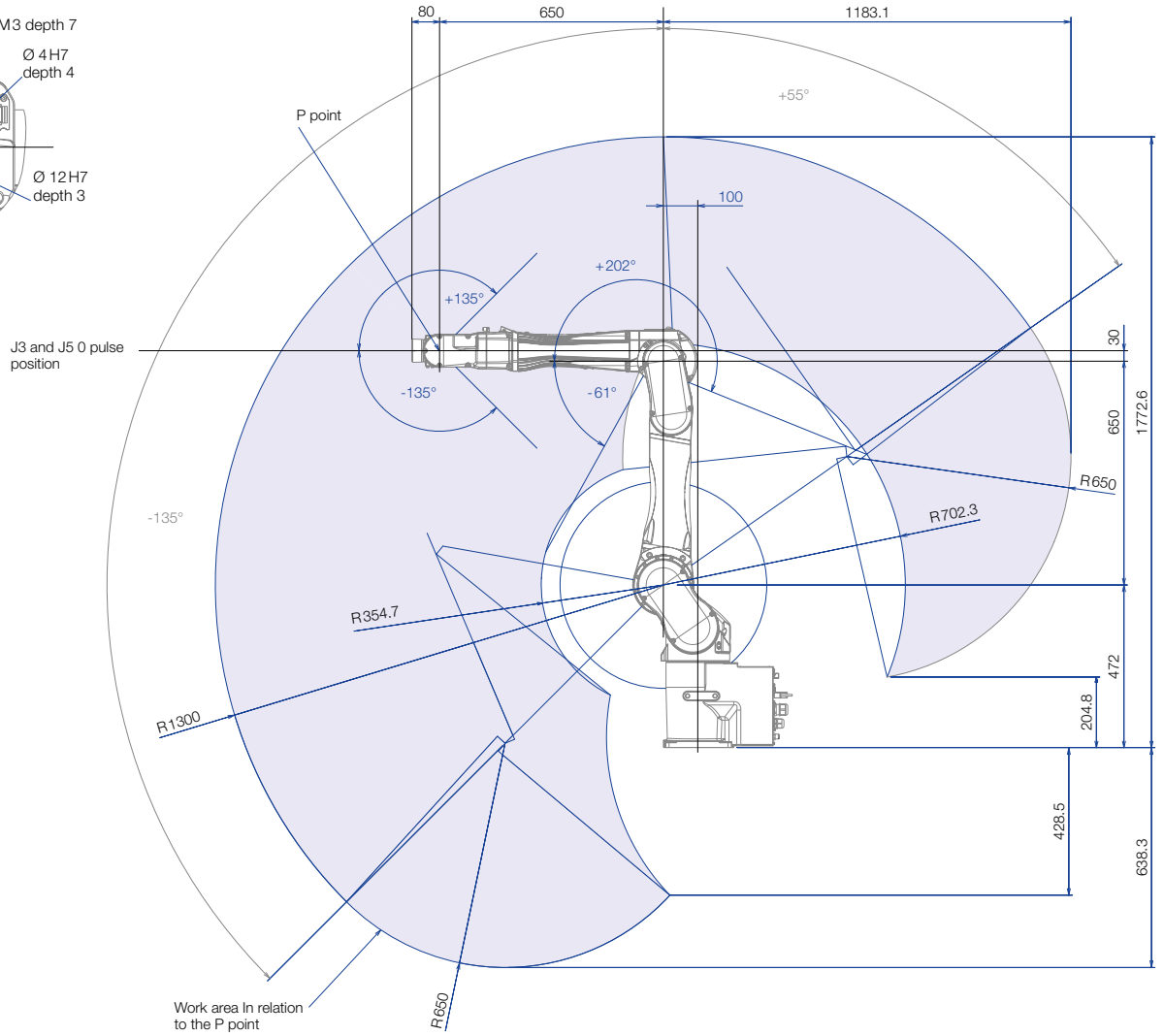

Front view

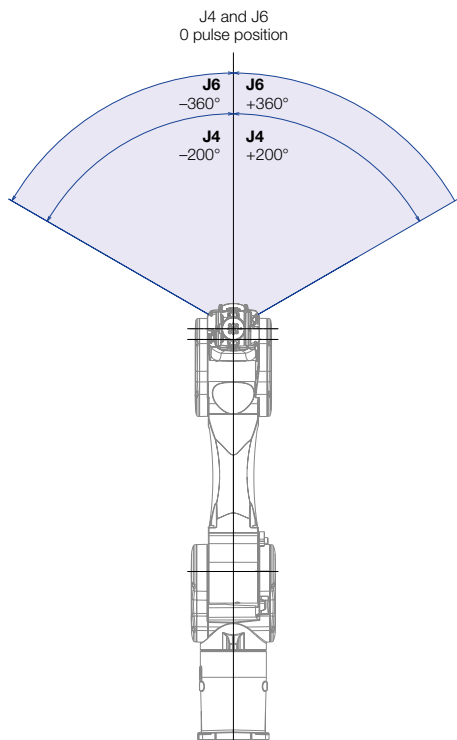

Top view

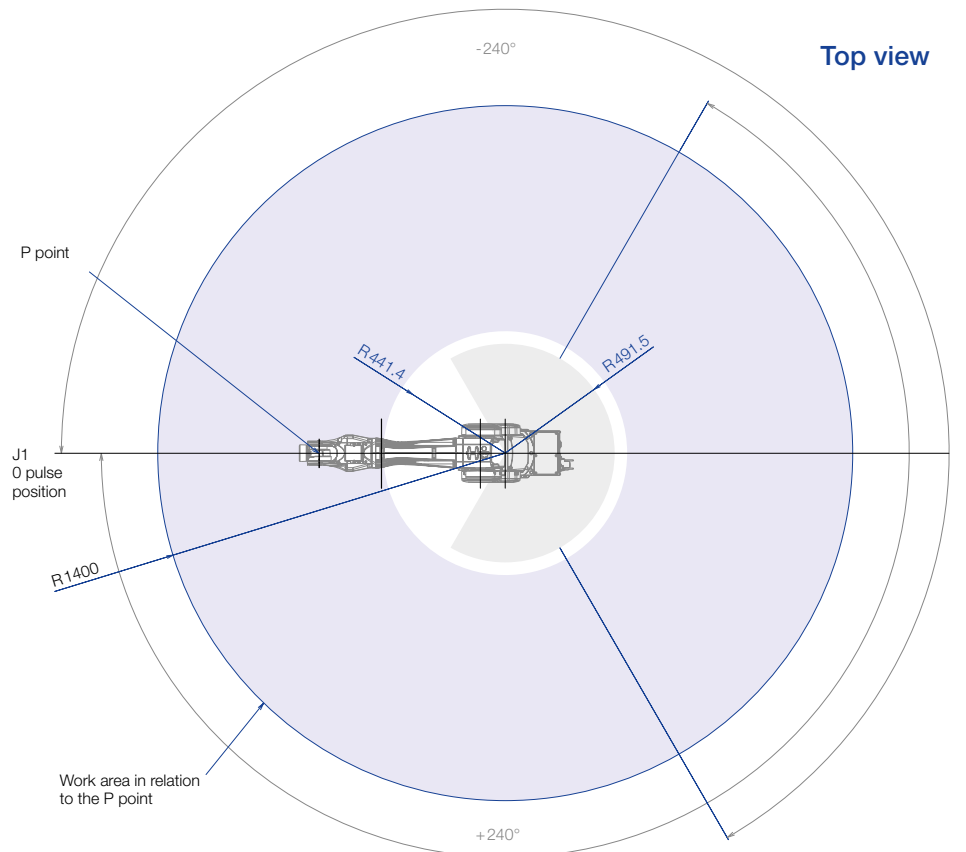

Simulation of robot cells

Good preparation is everything. Plan and visualise all procedures in your production, validate your program offline initially and carry out troubleshooting and editing work easily from your desk. With the Epson RC+ Simulator – included in the software package – you save time and money through all phases of your project.

Phase 1 Design

Plan your robot cell at full size in advance and work out the expected cycle time for your application to check feasibility before a single part for the system has been made. Plan future system expansions in the simulation system to keep downtime to a minimum.

Phase 2 Integration

Completing the program validation process before the robots are delivered enables you to create programs at the same time, with the system capable of displaying and evaluating even complex motions. Collision risks are identified and equipment damage is prevented.

Phase 3 Operation and maintenance

Troubleshoot and modify programs from your desk. Use the 3D layout to visualise collision detection, reachability checks and robot motions.

Even simpler designs using the CAD-to-Point function

The CAD-to-Point function allows CAD data to be converted into robot points.

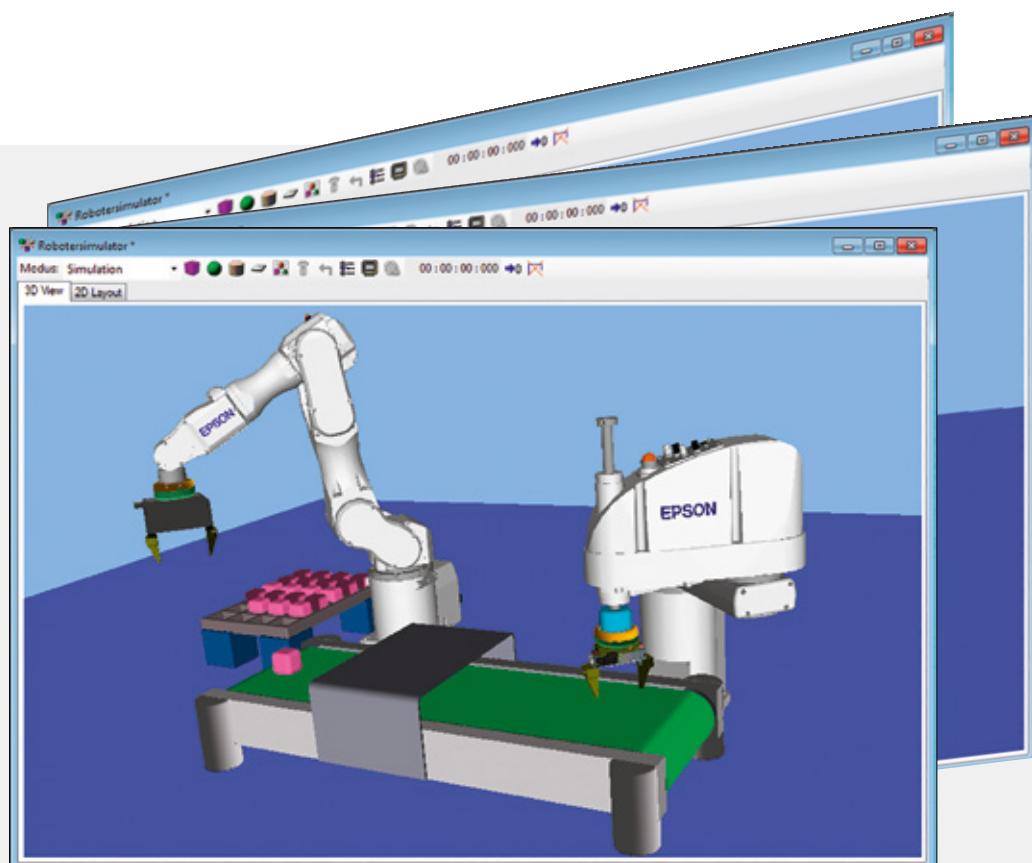
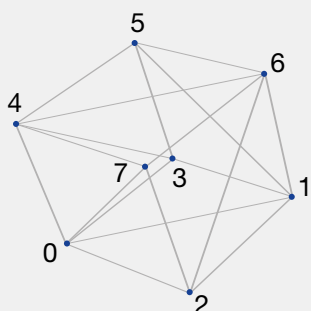

About Epson

Epson Robotic Solutions is one of the leading suppliers of high tech robot systems that are renowned worldwide for their reliability. The product range includes six-axis robots, SCARA robots, the SCARA entry-level LS and T models, the special Epson-developed Spider and N2 robots types, as well as the pioneering Dual Arm robot. Added to this are image processing controls and the Epson Force Sensor for force-controlled applications.

This gives Epson Robotic Solutions one of the most comprehensive ranges of high-precision industrial robots in the world, making them a technological pioneer for intelligently controlled automation processes.

Technological pioneer

1982

Epson SCARA robots freely available in Japan for the first time

1986

First class 1 cleanroom robot

1997

First PC-based controller

2008

Inventor of the right or left arm-optimised G3 SCARA robot

2009

Inventor of the spider – a unique SCARA robot with no dead zones

2013

First application of Epson QMEMS® sensors in robotics, reducing six-axis kinematics vibrations

2014

Epson Compact Vision CV2: Epson's own ultra-fast image processing computer

2016

Epson N2 series: World's first six-axis robot with folding arm - extremely compact and space-saving

2017

Epson Dual Arm robot with an arm geometry inspired by human physiology, as well as integrated sensors such as cameras, force sensors, and accelerometers

Pre- and after-sales support

Feasibility studies for maximum planning and project security

Support for planning and implementation

Introductory seminars, programming/maintenance courses, operator training

Inspection and individual maintenance concepts

Hotline service, on-site repair service

Central spare part stocking

Epson Industrial Solutions Center – find your solution

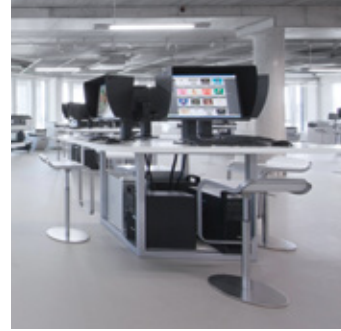

Experience all our Epson robots in action. Build, simulate and improve your automation application in a workshop cell, with help from our experts. The cell can be controlled and networked using all conventional fieldbus systems. In addition, we can supply you with modern peripherals such as a vision and conveyor tracking system.

Make an appointment

Call us on
+49 2159 538 1800

or send an email to
info.rs@epson.de

Epson Deutschland GmbH
Robotics Solutions Division
Otto-Hahn-Strasse 4
40670 Meerbusch

Phone: **+49 2159 5381800**
Fax: **+49 2159 5383170**
E-mail: **info.rs@epson.de**
www.epson.de/robots

Epson America Inc.
www.epsonrobots.com

Seiko Epson Corp
<http://global.epson.com/products/robots/>

Epson China Co, Ltd.
www.epson.com.cn/robots/

For more information please contact:

Home users: 0343 90 37766
Business users*: 0871 42 37766
Republic of Ireland: 01 436 7742

Or visit us at <https://www.epson.co.uk/contactus>

* 10p per minute plus network extras.

Trademarks and registered trademarks are the property of Seiko Epson Corporation or their respective owners.
Product information is subject to change without prior notice.